

### 3. Steady, One-dimensional Heat Conduction

Steady state: Temperature does not vary with time.

One dimensional: Temperature is a function of one dimension only, such as  $x$ .

#### 3.1 Slab with constant properties, such as $k$

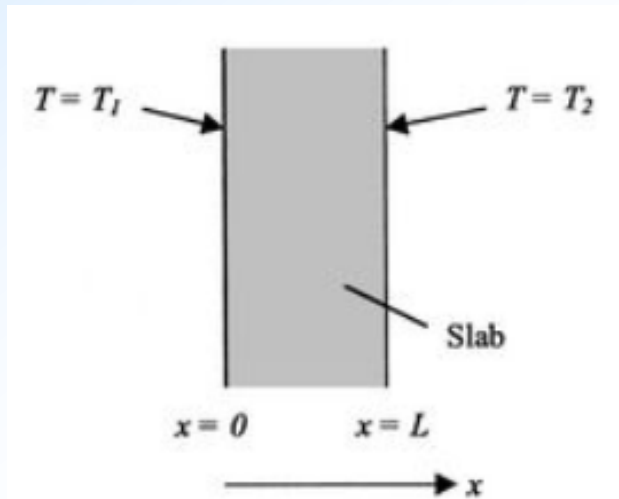

Differential equation with heat generation: 
$$\frac{d}{dx} \left( k \frac{dT}{dx} \right) + \dot{e}_{\text{gen}} = 0$$

Note that the partial differentials no longer exist which makes the solution simple.

The heat generation term can be a constant or a function of position (space variable)  $x$ .

The solution depends on the BC's that are used to find the const. of integration.

Differential equation  
without heat generation:

$$\frac{d}{dx} \left( k \frac{dT}{dx} \right) = 0$$

$$\frac{d^2T}{dx^2} = 0 \quad \text{for constant } k$$

### Example 1

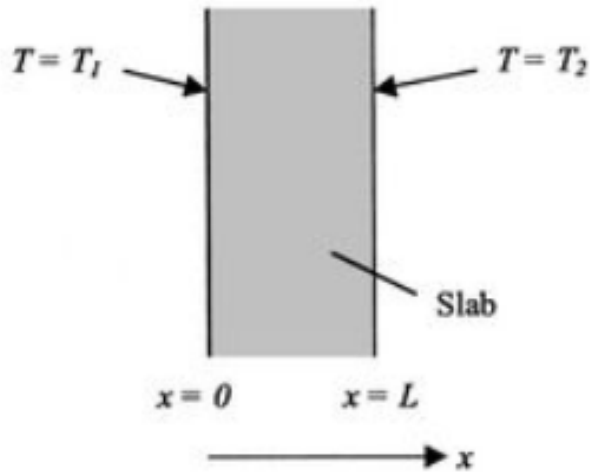

Determine  $T(x)$  and  $q$  for a slab with boundary surfaces at  $x = 0$  and  $x = L$  are kept at uniform temperatures  $T_1$  and  $T_2$ , respectively (no heat generation).

$$\frac{d^2T}{dx^2} = 0 \quad \text{in} \quad 0 \leq x \leq L \quad T(x) = C_1 x + C_2$$

$$\left. \begin{array}{l} \text{BC's: at } x = 0 \quad T(0) = T_1 \quad \Rightarrow \quad C_2 = T_1 \\ \text{at } x = L \quad T(L) = T_2 \quad \Rightarrow \quad C_1 = \frac{T_2 - T_1}{L} \end{array} \right\}$$

$$T(x) = \frac{T_2 - T_1}{L} x + T_1$$

Heat flux:  $\dot{q} = -k \frac{dT}{dx} = k \left( \frac{T_1 - T_2}{L} \right)$  Independent of  $x$

Heat flow rate:  $\dot{Q} = \dot{q} A = k A \left( \frac{T_1 - T_2}{L} \right)$  Independent of  $x$

If there is no heat generation, heat flux  $q$  and heat flow rate  $Q$  are independent of position ( $x$ ) (any geometry). Therefore,  $q$  and  $Q$  can be found by solving the Fourier equation only, taking  $q$  and/or  $Q$  constant (not a function of  $x$ ).

Re-solve  $\dot{q} = -k \frac{dT}{dx} \Rightarrow \dot{q} dx = -k dT \Rightarrow \int_0^L \dot{q} dx = \int_{T_1}^{T_2} -dT$

the Example

$$\dot{q} \int_0^L dx = \int_{T_1}^{T_2} -dT \Rightarrow \dot{q} = k \left( \frac{T_1 - T_2}{L} \right) \Rightarrow \dot{Q} = \frac{T_1 - T_2}{\frac{L}{k A}}$$

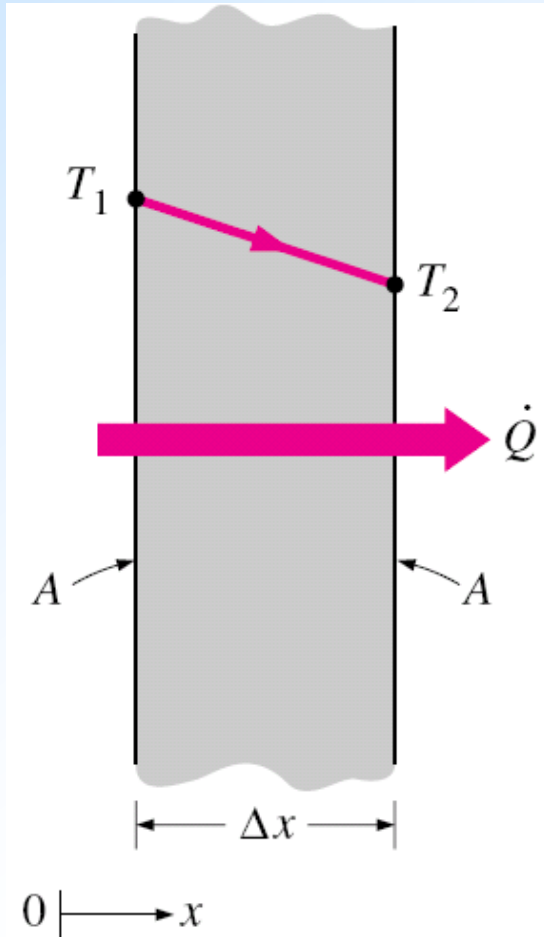

Temperature profile: 
$$T(x) = \frac{T_2 - T_1}{L} x + T_1$$

Heat flux 
$$\dot{q} = k \left( \frac{T_1 - T_2}{L} \right)$$

Heat flow rate: 
$$\dot{Q} = k A \frac{T_1 - T_2}{L} = \frac{T_1 - T_2}{\frac{L}{k A}}$$

## Example 2

Determine  $T(x)$  and  $q(x)$  for a slab with uniform heat generation,  $\dot{e}_{\text{gen}}$  in  $\text{W}/\text{m}^3$ . The boundary at surface  $x = 0$  is kept at a uniform temperature  $T_1$  and the boundary at  $x = L$  dissipates heat by convection into an environment at a constant temperature  $T_\infty$  with convective heat transfer coefficient  $h$ .

Differential equation: 
$$\frac{d^2T}{dx^2} + \frac{\dot{e}_{\text{gen}}}{k} = 0 \quad \text{in} \quad 0 \leq x \leq L$$

Boundary conditions: 1.  $T(0) = T_1$  at  $x = 0$

2.  $k \frac{dT}{dx} + h T(x) = h T_\infty$  at  $x = L$

Solution: 
$$\frac{dT}{dx} = - \frac{\dot{e}_{\text{gen}}}{k} x + C_1$$

$$T(x) = - \frac{\dot{e}_{\text{gen}}}{2k} x^2 + C_1 x + C_2$$

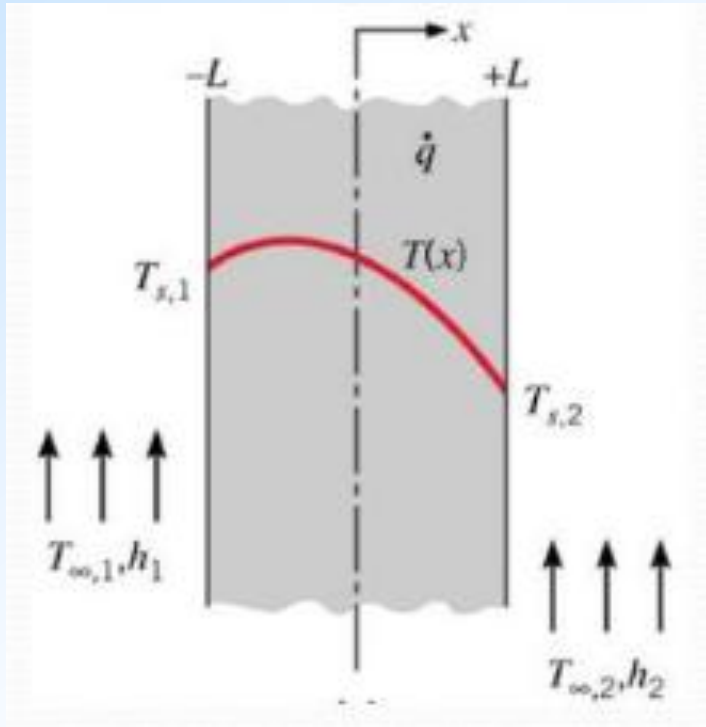

Apply Boundary conditions:

From (1):  $C_2 = T_1$

From (2):  $C_1 = \frac{(T_{\infty} - T_1) h}{k + h L} + \frac{\dot{e}_{\text{gen}} L (2 k + h L)}{2 k (k + h L)}$

This is a parabolic distribution

$$T(x) = - \frac{\dot{e}_{\text{gen}}}{2 k} x^2 + \left[ \frac{(T_{\infty} - T_1) h}{k + h L} + \frac{\dot{e}_{\text{gen}} L (2 k + h L)}{2 k (k + h L)} \right] x + T_1$$

Define a non-dimensional parameter called Biot number:  $Bi = \frac{h L}{k}$

$$T(x) - T_1 = \left( \frac{T_\infty - T_1}{1 + 1/Bi} \right) \frac{x}{L} + \frac{\dot{e}_{gen} L^2}{2k} \left[ \left( \frac{1 + 2/Bi}{1 + 1/Bi} \right) \frac{x}{L} - \left( \frac{x}{L} \right)^2 \right]$$

We shall return to the importance of the Biot number later on.

Heat flux:

$$q(x) = -k \frac{dT}{dx} = \dot{e}_{gen} x - C_1 k$$

Heat flux is a function of  $x$





Jean-Baptiste Biot

French Scientist

1774 - 1862



Note the following: When there is heat generation in the medium, the heat flux varies with position.

For most practical problems, the amount of heat flow at the boundaries is of interest.

Examine the cases when  $Bi \rightarrow \infty$  and when  $Bi \rightarrow 0$ :

When  $Bi \rightarrow \infty$  then  $h \rightarrow \infty$  and the boundary condition reduces to  $T(L) = T_\infty$ .

When  $Bi \rightarrow 0$  then  $h \rightarrow 0$  and the boundary condition reduces to  $dT/dx = 0$ .

That means that there is no heat flow through that surface at  $x = 0$ .

### Example 3

Consider an infinite plane wall (slab)  $2L$  thick, in which there is uniform volumetric heat generation rate,  $q'''$ . The wall surfaces are maintained at  $T = T_1$  at  $x = -L$  and  $T = T_2$  at  $x = +L$ . For constant thermal conductivity  $k$ , steady-state operating conditions, and defining the origin of the  $x$  coordinate from the centerline of the plane, show that the solution of the general conduction equation for the temperature distribution (profile) in the wall is

$$T(x) = \frac{q'''L^2}{2k} \left[ 1 - \left( \frac{x}{L} \right)^2 \right] + \frac{T_2 - T_1}{2} \left( \frac{x}{L} \right) + \frac{T_1 + T_2}{2}$$

### 3.2 Cylinder with constant properties, such as k

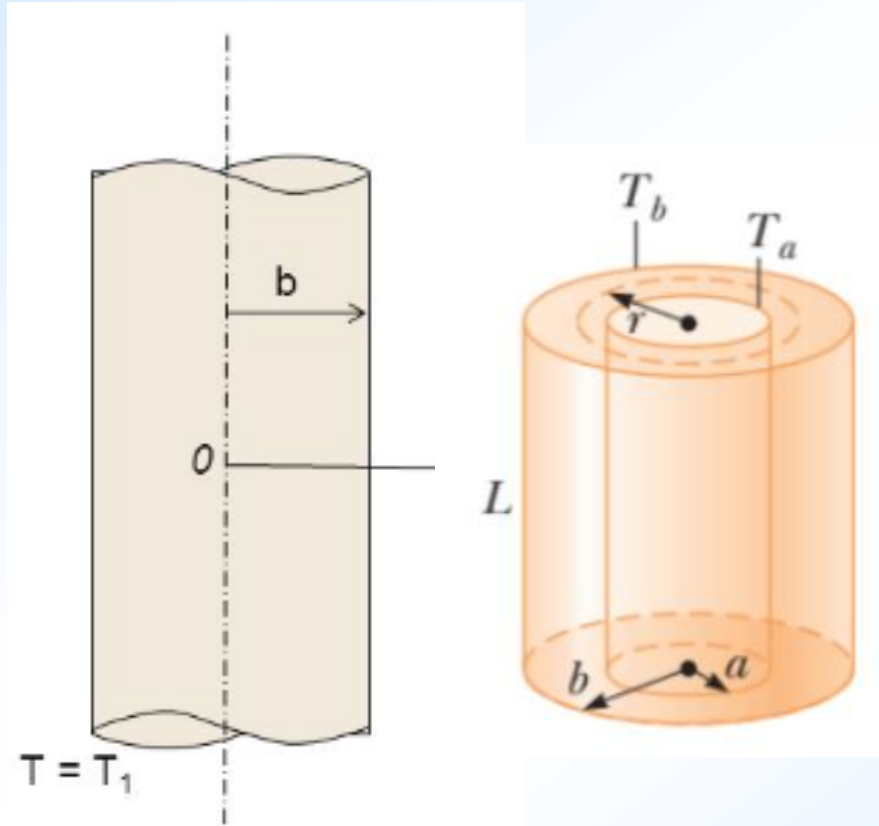

Solid cylinder

Hollow cylinder

Differential equation

$$\frac{1}{r} \frac{d}{dr} \left( r \frac{dT}{dr} \right) + \frac{\dot{e}_{gen}}{k} = 0$$

Heat flux  $\dot{q} = -k \frac{dT(r)}{dr}$

If positive, heat flow is in the positive  $r$  direction

For a solid cylinder, the solution of the differential equation requires two boundary conditions at  $r = 0$  and at  $r = b$ .

The boundary condition at  $r = b$  can be of any kind. For steady state, it cannot be an insulated surface BC. (Why?)

The boundary condition at the centre ( $r = 0$ ) is implicit. It is known as the symmetry condition. (Symmetry of what?):

$$\text{At } r = 0 \quad \frac{dT}{dr} = 0$$

or  $T$  is finite

### Example 4

Determine  $T(r)$  and  $q(b)$  for a solid cylinder with uniform heat generation,  $e_{\text{gen}}$  in  $\text{W/m}^3$ . The boundary at surface  $r = b$  is kept at a uniform temperature  $T_1$ .

Differential equation: 
$$\frac{1}{r} \frac{d}{dr} \left( r \frac{dT}{dr} \right) + \frac{\dot{e}_{\text{gen}}}{k} = 0 \quad \text{in} \quad 0 \leq r \leq b$$

Boundary conditions: 1.  $T(b) = T_1$  at  $r = b$

2.  $\frac{dT}{dr} = 0$  at  $r = 0$

Solution: 
$$\frac{d}{dr} \left( r \frac{dT}{dr} \right) = - \frac{\dot{e}_{\text{gen}}}{k} r \quad \Rightarrow \quad r \frac{dT}{dr} = - \frac{\dot{e}_{\text{gen}}}{k} r^2 + C_1$$

$$\frac{dT}{dr} = - \frac{\dot{e}_{\text{gen}}}{2k} r + \frac{C_1}{r} \quad \Rightarrow \quad T(r) = - \frac{\dot{e}_{\text{gen}}}{4k} r^2 + C_1 \ln(r) + C_2$$

From (2):  $C_1 = 0$

Apply Boundary conditions:

From (1):  $C_2 = T_1 + \frac{\dot{e}_{\text{gen}}}{4k} b^2$

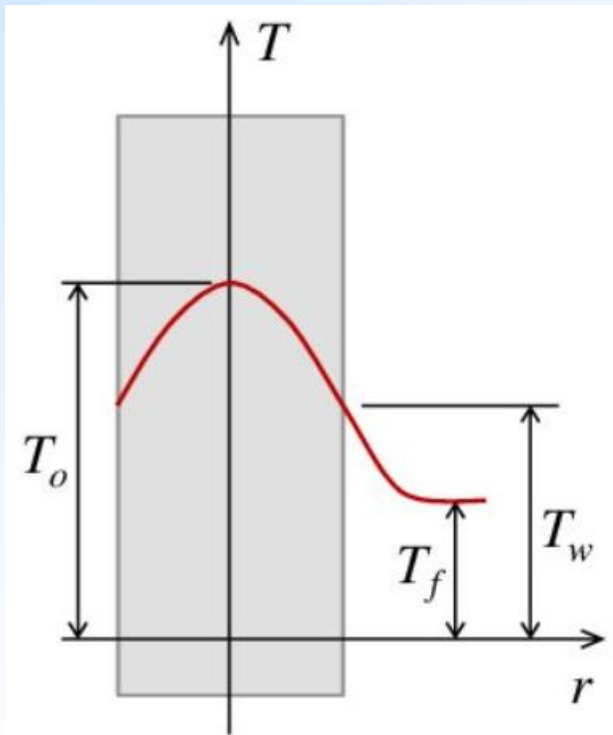

Temperature profile has a parabolic distribution:

$$T(r) = -\frac{\dot{e}_{\text{gen}}}{4k} r^2 + \frac{\dot{e}_{\text{gen}}}{4k} b^2 + T_w$$

Heat flux at the surface  $r = b$ :

$$q(r)|_{r=b} = -k \left. \frac{dT}{dr} \right|_{r=b} = -k \left( -\frac{\dot{e}_{\text{gen}}}{2k} b \right) = \frac{\dot{e}_{\text{gen}} b}{2}$$

## Example 5

Determine  $T(r)$  and the radial heat flow rate  $Q$  for a length  $L$  in a hollow cylinder with constant rate of heat generation,  $e_{\text{gen}}$  when the boundary at surfaces at  $r = a$  and  $r = b$  are kept at uniform temperatures  $T_a$  and  $T_b$ , respectively.

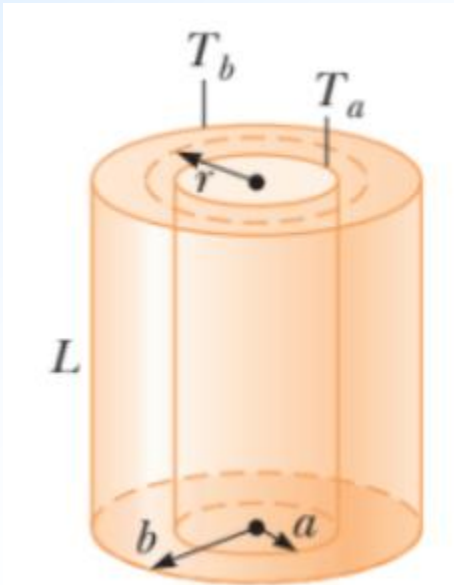

Differential equation:

$$\frac{1}{r} \frac{d}{dr} \left( r \frac{dT}{dr} \right) + \frac{\dot{e}_{\text{gen}}}{k} = 0 \quad \text{in } a \leq r \leq b$$

Boundary conditions:

1.  $T(a) = T_a$  at  $r = a$
2.  $T(b) = T_b$  at  $r = b$

Solution: 
$$T(r) = - \frac{\dot{e}_{\text{gen}}}{4k} r^2 + C_1 \ln(r) + C_2$$



Apply boundary conditions:

$$T(r) = - \frac{\dot{e}_{\text{gen}}}{4 k} r^2 + \frac{(T_b - T_a) + \frac{\dot{e}_{\text{gen}}}{4 k} (b^2 - a^2)}{\ln\left(\frac{b}{a}\right)} \ln(r) + \left( T_a + \frac{\dot{e}_{\text{gen}} a^2}{4 k} \right) - \left[ (T_b - T_a) + \frac{\dot{e}_{\text{gen}}}{4 k} (b^2 - a^2) \right] \frac{\ln(a)}{\ln\left(\frac{b}{a}\right)}$$

The radial heat flow rate at any position  $r$  through the cylinder for a length of  $H$  is:

$$Q(r) = q(r) (\text{Area}) = - k \frac{dT}{dr} (2 \pi r L) = 2 \pi L \left( \frac{\dot{e}_{\text{gen}}}{2} r^2 - C_1 k \right)$$

Show that if there is no heat generation, the heat flow rate is independent of the radial position  $r$ .

### 3.3 Sphere with constant properties, such as k

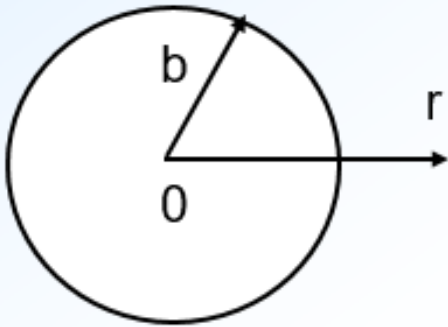

Differential equation 
$$\frac{1}{r^2} \frac{d}{dr} \left( r^2 \frac{dT}{dr} \right) + \frac{\dot{e}_{\text{gen}}}{k} = 0$$

Heat flux 
$$\dot{q} = -k \frac{dT(r)}{dr}$$

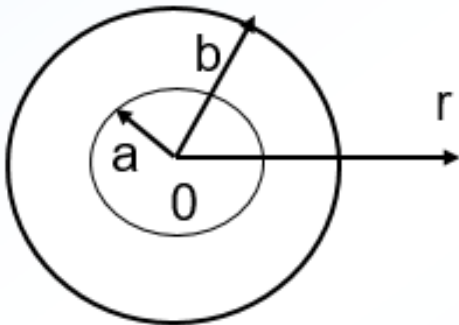

The considerations for the boundary conditions (such as symmetry at  $r = 0$ ) is the same as that of a cylinder.

## Example 6

Determine  $T(r)$  and the total radial heat flow rate  $Q$  in a hollow sphere when the surfaces at  $r = a$  and  $r = b$  are kept at uniform temperatures  $T_a$  and  $T_b$ , respectively.

(No heat generation.)

Differential equation: 
$$\frac{d}{dr} \left( r^2 \frac{dT}{dr} \right) = 0 \quad \text{in} \quad a \leq r \leq b$$

Boundary conditions:

1.  $T(a) = T_a$  at  $r = a$
2.  $T(b) = T_b$  at  $r = b$

Solution: 
$$\frac{d}{dr} \left( r^2 \frac{dT}{dr} \right) = 0 \Rightarrow r^2 \frac{dT}{dr} = C_1 \Rightarrow T(r) = -\frac{C_1}{r} + C_2$$

Apply boundary conditions: 
$$T_a = -\frac{C_1}{a} + C_2 \quad T_b = -\frac{C_1}{b} + C_2$$

Apply boundary conditions:  $C_1 = \frac{a b}{a - b} (T_a - T_b)$        $C_2 = \frac{b T_b - a T_a}{b - a}$

Temperature profile:  $T(r) = \frac{1}{b - a} \left[ a T_a \left( \frac{b}{r} - 1 \right) + b T_b \left( 1 - \frac{a}{r} \right) \right]$

Radial heat flow rate:  $\dot{Q} = \dot{q}(r) (\text{Area}) = -k \frac{dT}{dr} (4 \pi r^2) = -4 \pi k C_1$

$$\dot{Q} = 4 \pi k \frac{a b}{a - b} (T_a - T_b)$$

Q is independent of position, i.e., it can be found with Fourier equation only, as before.

### 3.4 The Concept of Thermal Resistance

The total heat flow rate through a solid can be related to thermal resistance if these assumptions are true:

- One-dimensional, steady-state heat conduction;
- Finite regions;
- No heat generation;
- Constant thermal conductivity; and
- Prescribed temperatures at the boundaries.

If so, then  $\dot{Q} = \frac{\Delta T}{R}$  where

- $\Delta T$ : Difference between temperatures at the boundaries
- $R$ : Thermal resistance in  $^{\circ}\text{C} / \text{W}$

The thermal resistance is analogous to electrical resistance defined by:

Current =  $\frac{\text{Electric potential difference}}{\text{Electric resistance}}$        $I = \frac{\Delta V}{R}$       Similarly:       $Q = \frac{\Delta T}{R}$

### 3.4.1 For the Slab

From Example 1       $\dot{Q} = A k \frac{T_1 - T_2}{L} = \frac{T_1 - T_2}{\frac{L}{A k}}$

$R_{\text{slab}} = \frac{L}{A k}$

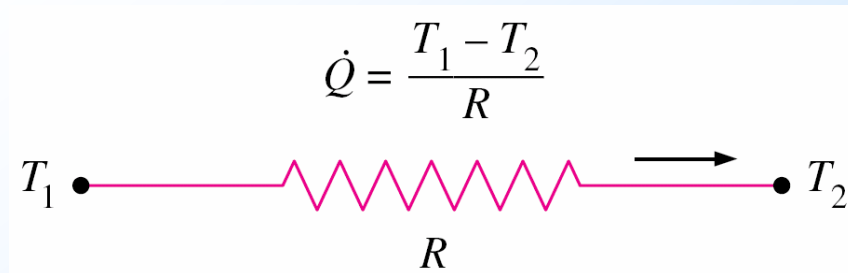
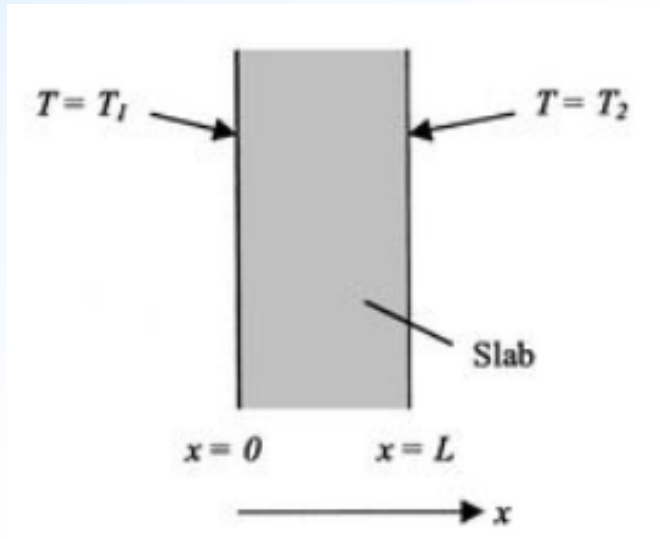

## Slab with convective boundaries

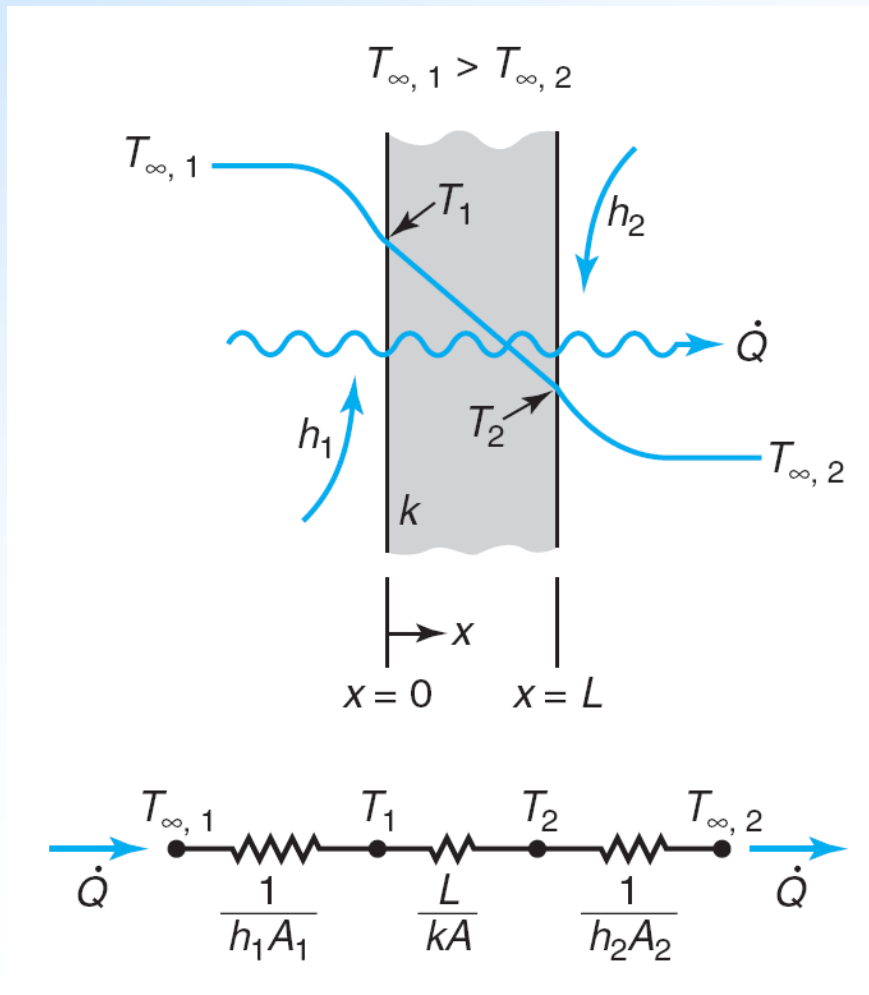

$$\dot{Q} = A h_1 (T_{\infty,1} - T_1) = \frac{T_{\infty,1} - T_1}{\frac{1}{A h_1}}$$

$$\dot{Q} = A k \left( \frac{T_1 - T_2}{L} \right) = \frac{T_1 - T_2}{\frac{L}{A k}}$$

$$\dot{Q} = A h_2 (T_2 - T_{\infty,2}) = \frac{T_2 - T_{\infty,2}}{\frac{1}{A h_2}}$$

Note that it is the same  $Q$ .



## Example 7

A furnace wall 200 mm thick is made of a material having thermal conductivity of 1.45 W/m.K. The inner and outer surface are exposed to average temperatures of 3500 °C and 400 °C, respectively. If the gas and air film coefficients are 58 and 11.63 W/m<sup>2</sup>.K, respectively, find the rate of heat transfer through a wall of 2.5 square meters. Also, find the temperatures on the two sides of the wall.

$$\dot{Q} = \frac{T_{\infty,1} - T_{\infty,2}}{\frac{1}{A h_1} + \frac{L}{A k} + \frac{1}{A h_2}} = \frac{350 - 40}{\frac{1}{(2)(58)} + \frac{0.2}{(2)(1.45)} + \frac{1}{(2)(11.63)}}$$
$$= 3214 \text{ W}$$

$$\dot{Q} = 3214 \text{ W} = A h_1 (T_{\infty,1} - T_1) = (2)(58)(350 - T_1)$$
$$= A h_2 (T_2 - T_{\infty,2}) = (2)(11.63)(T_2 - 40)$$
$$\left. \begin{array}{l} T_1 = 327.84 \text{ }^\circ\text{C} \\ T_2 = 150.5 \text{ }^\circ\text{C} \end{array} \right\}$$

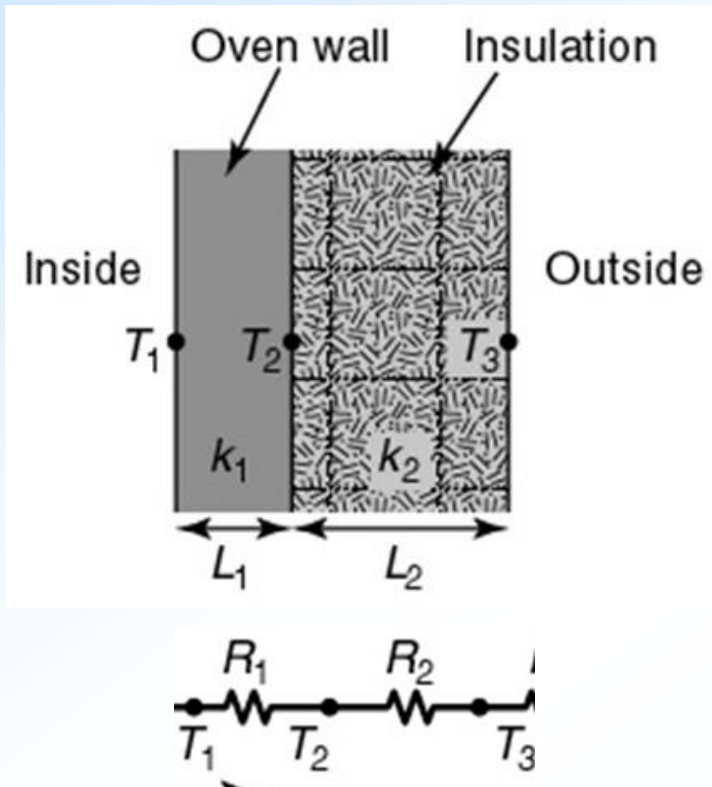

Steady, one-dim. heat conduction through multi-layered slabs:

$$\dot{Q}_{\text{cond}} = k_1 A \frac{T_1 - T_2}{L_1} = k_2 A \frac{T_2 - T_3}{L_2}$$

$$\dot{Q}_{\text{cond}} = \frac{T_1 - T_2}{L_1/k_1 A} = \frac{T_2 - T_3}{L_2/k_2 A}$$

$$\dot{Q}_{\text{cond}} = \frac{T_1 - T_2}{R_1} = \frac{T_2 - T_3}{R_2} = \frac{T_1 - T_3}{R_1 + R_2}$$

$$R_{\text{cond}} = R_1 + R_2 = \frac{L_1}{k_1 A} + \frac{L_2}{k_2 A}$$

**Steady, one-dimensional heat conduction through multi-layered slabs:**

$A_B + A_C = A_A = A_D$   
 $L_B = L_C$

$$\dot{Q}_{\text{cond}} = \frac{T_1 - T_2}{R_{\text{total}}}$$

$$R_{\text{total}} = R_A + \frac{1}{\frac{1}{R_B} + \frac{1}{R_C}} + R_D$$

### 3.4.2 For the Hollow Cylinder

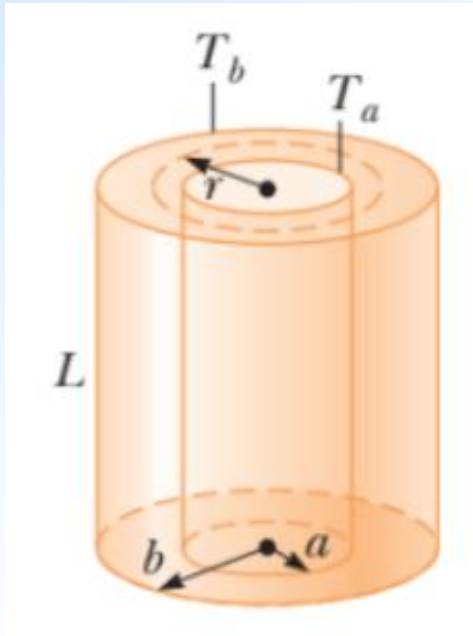

From Example 4  $\dot{Q} = 2 \pi L \left( \frac{\dot{e}_{\text{gen}}}{2} r^2 - C_1 k \right)$

$$\dot{e}_{\text{gen}} = 0 \Rightarrow \dot{Q} = 2 \pi L (-C_1 k)$$

$$C_1 = \frac{T_b - T_a}{\ln\left(\frac{b}{a}\right)} \Rightarrow \dot{Q} = \frac{2 \pi L}{\ln\left(\frac{b}{a}\right)} (T_a - T_b)$$

$$R_{\text{cyl}} = \frac{\ln\left(\frac{b}{a}\right)}{2 \pi L k}$$

This can be re-arranged to take a similar form as that of a slab:

$$R_{\text{cyl}} = \frac{L_{\text{cyl}}}{A_{\text{cyl}} k}$$

Where:  $L_{\text{cyl}} = b - a$       Thickness of the cylinder

$$A_{\text{cyl}} = \frac{A_b - A_a}{\ln\left(\frac{A_b}{A_a}\right)}$$

Logarithmic mean area

$$A_b = 2 \pi b L$$

$$A_a = 2 \pi a L$$

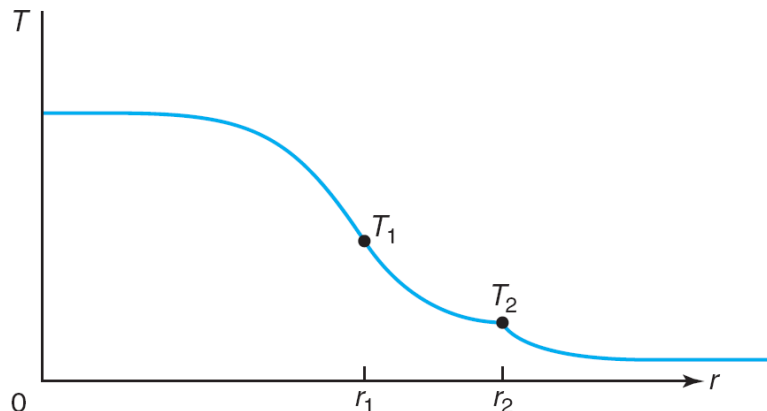
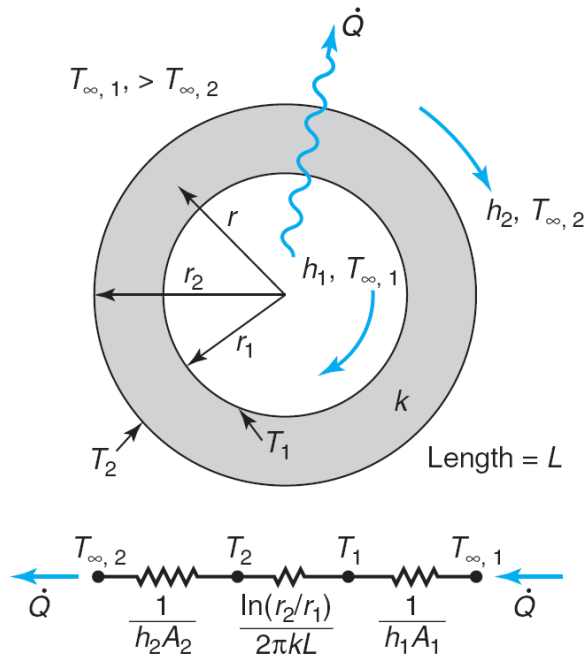

## Hollow cylinder with convective boundaries

$$\dot{Q} = A_1 h_1 (T_{\infty,1} - T_1) = \frac{T_{\infty,1} - T_1}{\frac{1}{A_1 h_1}}$$

$$\dot{Q} = 2 \pi k L \left( \frac{T_1 - T_2}{\ln\left(\frac{r_2}{r_1}\right)} \right) = \frac{T_1 - T_2}{\frac{\ln\left(\frac{r_2}{r_1}\right)}{2 \pi k L}}$$

$$\dot{Q} = A_2 h_2 (T_2 - T_{\infty,2}) = \frac{T_2 - T_{\infty,2}}{\frac{1}{A_2 h_2}}$$

Note that it is the same Q.

## Example 8

A steam pipe of inner diameter 200 mm is covered with 50 mm thick high insulated material of thermal conductivity  $k = 0.01 \text{ W/m}\cdot\text{°C}$ . The inner and outer surface temperatures maintained at  $500 \text{ °C}$  and  $100 \text{ °C}$ , respectively. Calculate the total heat loss per meter length of pipe?

$$\left. \begin{aligned} r_1 &= \frac{200}{2} = 100 \text{ mm} \\ r_2 &= \frac{200 + 100}{2} = 150 \text{ mm} \end{aligned} \right\} \dot{Q} = \frac{T_1 - T_2}{\frac{\ln\left(\frac{r_2}{r_1}\right)}{2 \pi k L}} = \frac{500 - 100}{\frac{\ln\left(\frac{0.15}{0.1}\right)}{2 \pi (0.01) (1)}} = 61.98 \text{ W}$$



### 3.4.3 For the Hollow Sphere

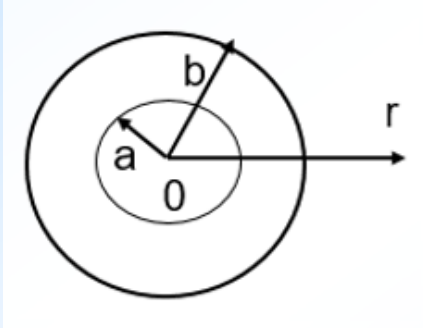

From Example 5  $\dot{Q} = 4 \pi k \frac{a b}{b - a} (T_a - T_b)$

$$R_{\text{sph}} = \frac{1}{4 \pi k} \frac{b - a}{a b}$$

This can be re-arranged:

$$R_{\text{sph}} = \frac{L_{\text{sph}}}{A_g k}$$

Where:  $L_{\text{sph}} = b - a$

Thickness of the sphere

$$A_g = \sqrt{A_a A_b}$$

Geometric mean area

$$A_b = 4 \pi b^2 \quad A_a = 4 \pi a^2$$

## Example 9

A spherical shaped vessel of 1.2 m diameter is 100 mm thick. Find the rate of heat leakage, if the temperature difference between the inner and outer surface is 200 °C. Thermal conductivity of the material of sphere is 0.3 kJ/h.m.°C.

$$\left. \begin{aligned} b &= \frac{1.2}{2} = 0.6 \text{ m} \\ a &= \frac{1.2 - (2)(0.1)}{2} = 0.5 \text{ m} \end{aligned} \right\} \begin{aligned} \dot{Q} &= 4 \pi k \frac{a b}{b - a} (T_a - T_b) \\ &= 4 \pi (0.3) \frac{(0.5)(0.6)}{0.6 - 0.5} (200) = 2262 \text{ kJ/h} \end{aligned}$$

### 3.5 Composite Medium

If heat transfer takes place through a medium composed of several different layers, connected in parallel or in series, with the same or different thermal conductivities, the rate of heat flow can be calculated using the thermal resistance concept.

In addition to the previous assumptions, add the following:

- Perfect thermal contact (no temperature drop at the interfaces of the layers);
- Interior and exterior surfaces of the structures are subjected to convective heat transfer to fluids at constant mean temperatures  $T_{\infty,1}$  and  $T_{\infty,2}$ , and with convective heat transfer coefficients  $h_1$  and  $h_2$ .

### 3.5.1 Slabs Connected in Parallel

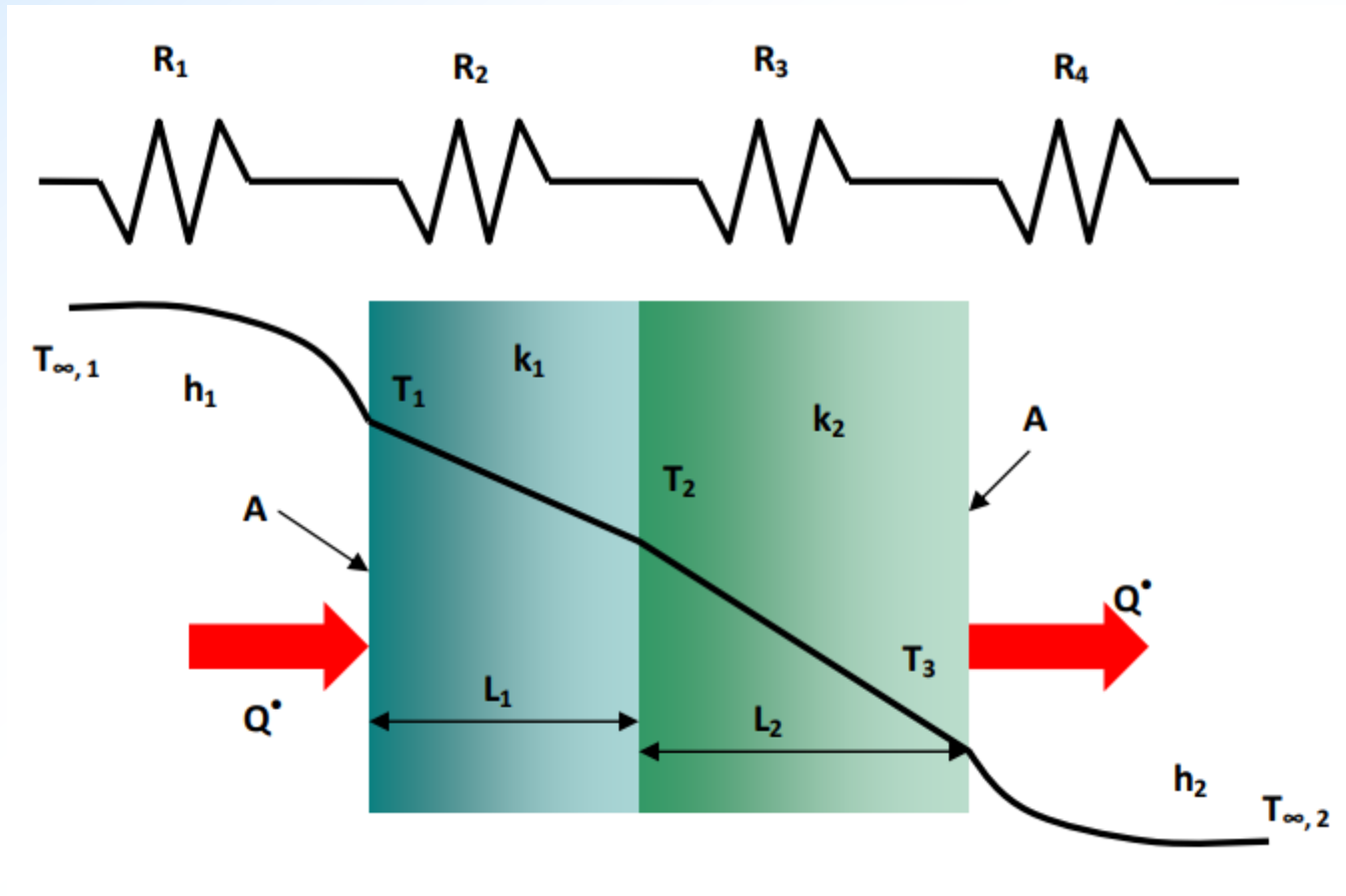

The heat transfer rate,  $Q$ , through an area  $A$  of this composite structure is the same through each layer.

$$\dot{Q} = A h_1 (T_{\infty,1} - T_1) = A k_1 \frac{T_1 - T_2}{L_1} = A k_2 \frac{T_2 - T_3}{L_2} = A h_2 (T_3 - T_{\infty,2})$$

In terms of thermal resistances:

$$\dot{Q} = \frac{T_{\infty,1} - T_1}{\frac{1}{A h_1}} = \frac{T_1 - T_2}{\frac{L_1}{A k_1}} = \frac{T_2 - T_3}{\frac{L_2}{A k_2}} = \frac{T_3 - T_{\infty,2}}{\frac{1}{A h_2}}$$

$$\dot{Q} = \frac{T_{\infty,1} - T_1}{R_1} = \frac{T_1 - T_2}{R_2} = \frac{T_2 - T_3}{R_3} = \frac{T_3 - T_{\infty,2}}{R_4}$$

Define total resistance,  $R = R_1 + R_2 + R_3 + R_4$

$$\dot{Q} = \frac{T_{\infty,1} - T_1}{R_1} = \frac{T_1 - T_2}{R_2} = \frac{T_2 - T_3}{R_3} = \frac{T_3 - T_{\infty,2}}{R_4} = \frac{T_{\infty,1} - T_{\infty,2}}{R_{\text{total}}}$$

Define **Overall Heat Transfer Coefficient**,  $U$ :

$$\dot{Q} = A U (T_{\infty,1} - T_{\infty,2}) = \frac{T_{\infty,1} - T_{\infty,2}}{\frac{1}{AU}} = \frac{T_{\infty,1} - T_{\infty,2}}{R_{\text{total}}}$$

$$U = \frac{1}{A R_{\text{total}}} = \frac{1}{\frac{1}{h_1} + \frac{L_1}{k_1} + \frac{L_2}{k_2} + \frac{1}{h_2}}$$

### 3.5.2 Slabs Connected in Series

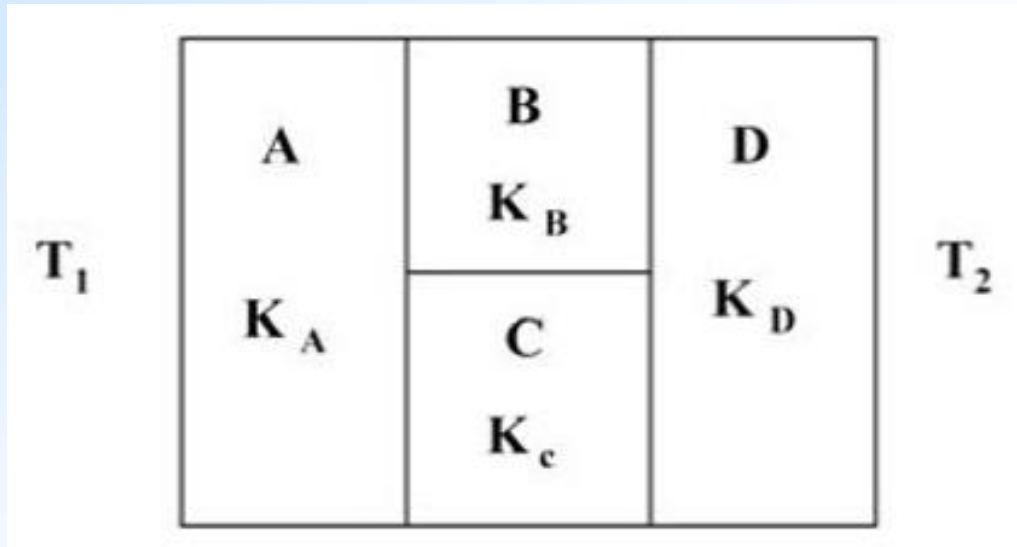

$$L_B = L_C$$

$$A_A = A_B + A_C = A_D$$

$$\dot{Q} = \frac{T_1 - T_2}{R_{total}}$$

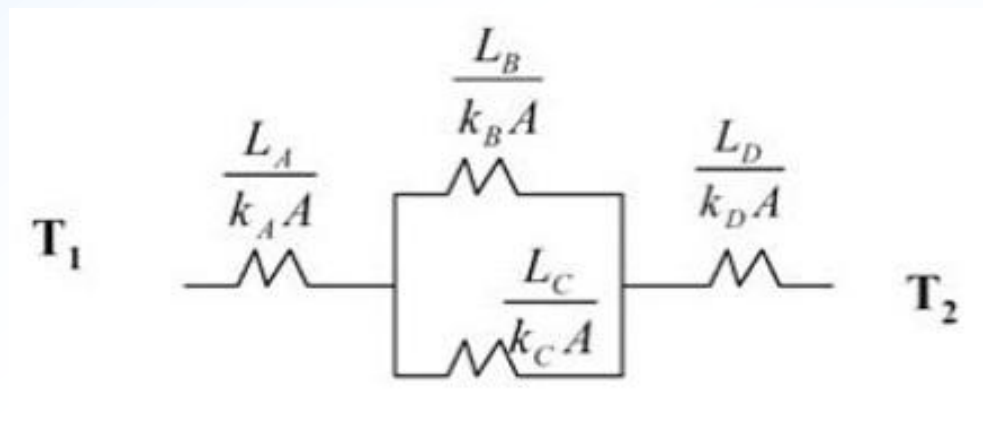

$$R_{total} = R_A + \frac{1}{\frac{1}{R_B} + \frac{1}{R_C}} + R_D$$



## Example 10

A composite wall consists of three layers of thicknesses 300 mm, 200 mm and 100 mm with thermal conductivities 1.5, 3.5, and is  $W/m.K$ , respectively. The inside surface is exposed to gases at  $1200\text{ }^{\circ}C$  with convection heat transfer coefficient as  $30\text{ }W/m^2.K$ . The temperature of air on the other side of the wall is  $30\text{ }^{\circ}C$  with convective heat transfer coefficient  $10\text{ }W/m^2.K$ . If the temperature at the outside surface of the wall is  $180\text{ }^{\circ}C$ , calculate the temperature at other surface of the wall, the rate of heat transfer, and the overall heat transfer coefficient.

### 3.5.3 Coaxial Cylinders

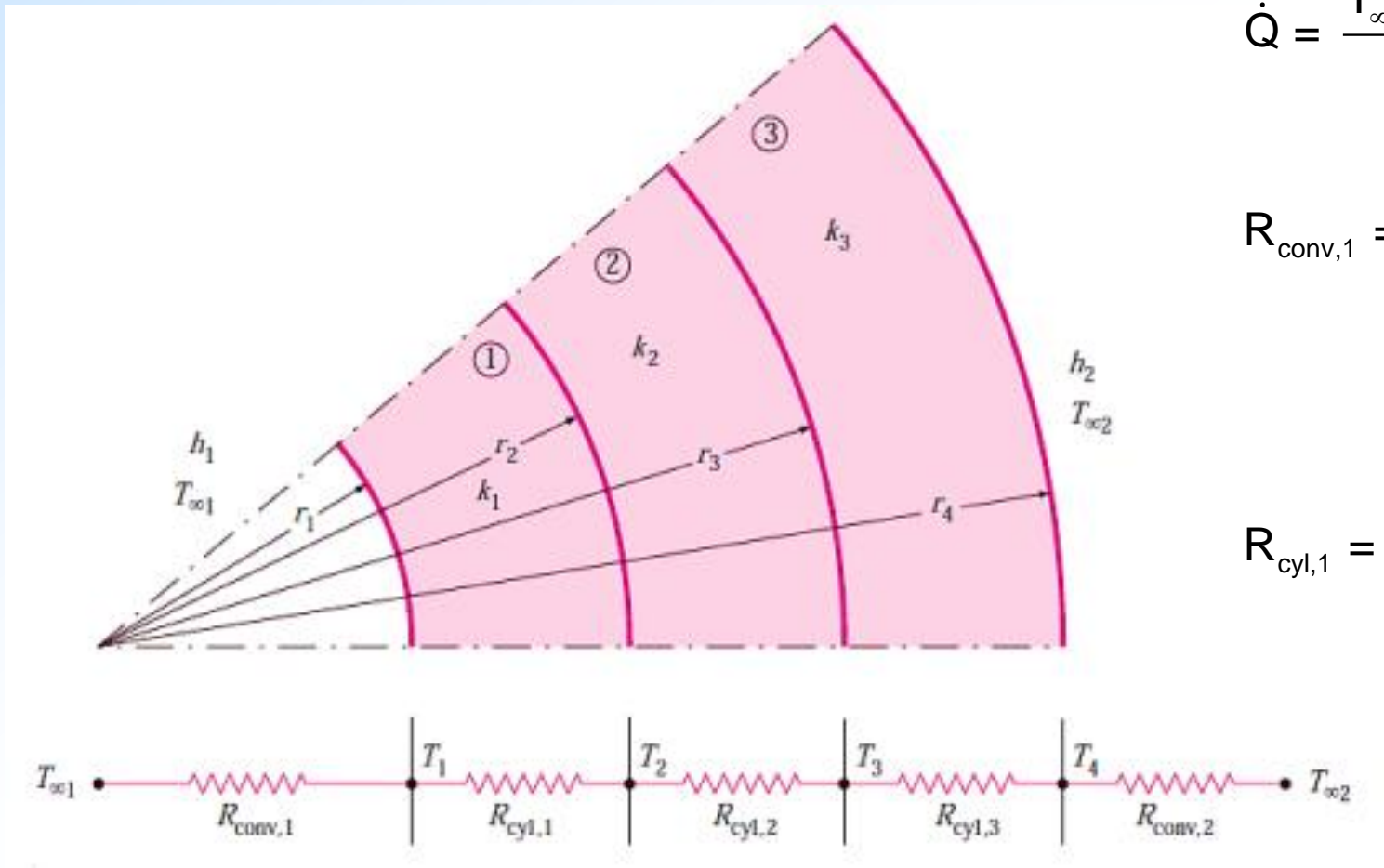

$$\dot{Q} = \frac{T_{\infty,1} - T_{\infty,2}}{R_{total}}$$

$$R_{conv,1} = \frac{1}{2 \pi r_1 L h_1}$$

$$R_{cy1,1} = \frac{\ln\left(\frac{r_2}{r_1}\right)}{2 \pi L k_1}$$

$$\dot{Q} = \frac{T_{\infty,1} - T_{\infty,2}}{R_{\text{total}}}$$

$$R_{\text{total}} = R_{\text{conv},1} + R_{\text{cyl},1} + R_{\text{cyl},2} + R_{\text{cyl},3} + R_{\text{conv},2}$$

$$R_{\text{conv},1} = \frac{1}{2 \pi r_1 L h_1}$$

$$R_{\text{conv},2} = \frac{1}{2 \pi r_4 L h_2}$$

$$R_{\text{cyl},1} = \frac{\ln\left(\frac{r_2}{r_1}\right)}{2 \pi L k_1}$$

$$R_{\text{cyl},2} = \frac{\ln\left(\frac{r_3}{r_2}\right)}{2 \pi L k_2}$$

$$R_{\text{cyl},3} = \frac{\ln\left(\frac{r_4}{r_3}\right)}{2 \pi L k_3}$$

The overall heat transfer coefficient,  $U$ , can be defined in two ways:

$$U_1 = \frac{1}{A_1 R_{\text{total}}} = \frac{1}{2 \pi r_1 L R_{\text{total}}}$$

based on interior surface area

$$U_2 = \frac{1}{A_4 R_{\text{total}}} = \frac{1}{2 \pi r_4 L R_{\text{total}}}$$

based on outer surface area

For most engineering problems, the overall heat transfer coefficient,  $U$ , is based on the external (outer) surface area because the outer diameter can be easily measured.

$$U_2 = \frac{1}{A_4 R_{\text{total}}} = \frac{1}{2 \pi r_4 L R_{\text{total}}}$$

$$U_2 = \frac{1}{\frac{r_4}{r_1} \frac{1}{h_1} + \frac{r_4}{k_1} \ln\left(\frac{r_2}{r_1}\right) + \frac{r_4}{k_2} \ln\left(\frac{r_3}{r_2}\right) + \frac{r_4}{k_3} \ln\left(\frac{r_4}{r_3}\right) + \frac{1}{h_2}}$$



## Example 11

A steel tube of 5 cm ID (inner diameter) and 7 cm OD (outer diameter) is covered with 2.5 cm layer of insulation. The inside surface of the tube receives heat by convection from a hot gas while the outer surface of the insulation is exposed to the ambient air. Determine

- The heat loss to the ambient air per 3 m length of the tube; and
- The temperature drops across the tube material and the insulation layer.

Data:  $T_{\infty,1} = 300 \text{ }^{\circ}\text{C}$        $h_1 = 284 \text{ W/m}^2\cdot\text{K}$       Neglect radiation.

$T_{\infty,2} = 30 \text{ }^{\circ}\text{C}$        $h_2 = 17 \text{ W/m}^2\cdot\text{K}$

(a) Radial heat flow

$$\dot{Q} = \frac{T_{\infty,1} - T_{\infty,2}}{R_{\text{total}}}$$

through the tube:

$$R_{\text{total}} = R_{\text{conv},1} + R_{\text{cyl},1} + R_{\text{cyl},2} + R_{\text{conv},2}$$

$$R_{\text{conv},1} = \frac{1}{2 \pi r_1 L h_1} = \frac{1}{2 \pi (0.025) (3) (284)} = 7.47 \cdot 10^{-3} \text{ } ^\circ\text{C} / \text{W}$$

$$R_{\text{cyl},1} = \frac{\ln\left(\frac{r_2}{r_1}\right)}{2 \pi L k_1} = \frac{\ln\left(\frac{3.5}{2.5}\right)}{2 \pi (3) (43.26)} = 4.13 \cdot 10^{-4} \text{ } ^\circ\text{C} / \text{W}$$

$$R_{\text{cyl},2} = \frac{\ln\left(\frac{r_3}{r_2}\right)}{2 \pi L k_2} = \frac{\ln\left(\frac{(3.5+2.5)}{3.5}\right)}{2 \pi (3) (0.208)} = 1.375 \cdot 10^{-1} \text{ } ^\circ\text{C} / \text{W}$$

$$R_{\text{conv},2} = \frac{1}{2 \pi r_2 L h_2} = \frac{1}{2 \pi (0.035 + 0.025) (3) (17)} = 5.35 \cdot 10^{-2} \text{ } ^\circ\text{C} / \text{W}$$

$$R_{\text{total}} = R_{\text{conv},1} + R_{\text{cyl},1} + R_{\text{cyl},2} + R_{\text{conv},2} = 0.197 \text{ } ^\circ\text{C} / \text{W}$$

$$\dot{Q} = \frac{T_{\infty,1} - T_{\infty,2}}{R_{\text{total}}} = \frac{300 - 30}{0.197} = 1368 \text{ W}$$

(b) Temperature drops

$$\Delta T_{\text{tube}} = \frac{R_{\text{cyc},1}}{R_{\text{total}}} (T_{\infty,1} - T_{\infty,2}) = \frac{4.13 \cdot 10^{-4}}{0.197} (300 - 30) = 0.564 \text{ } ^\circ\text{C}$$

$$\Delta T_{\text{ins}} = \frac{R_{\text{cyc},2}}{R_{\text{total}}} (T_{\infty,1} - T_{\infty,2}) = \frac{1.375 \cdot 10^{-1}}{0.197} (300 - 30) = 188 \text{ } ^\circ\text{C}$$

Note the  
difference in  
temperature  
drop

## Example 12

A nuclear fuel rod assembly, consists of an outer cladding and the inner nuclear material, as shown in the figure.

- Determine the temperature at the assembly surface (in °C)
- Determine the temperature at the interface between the inner nuclear material and the outer cladding (in °C)

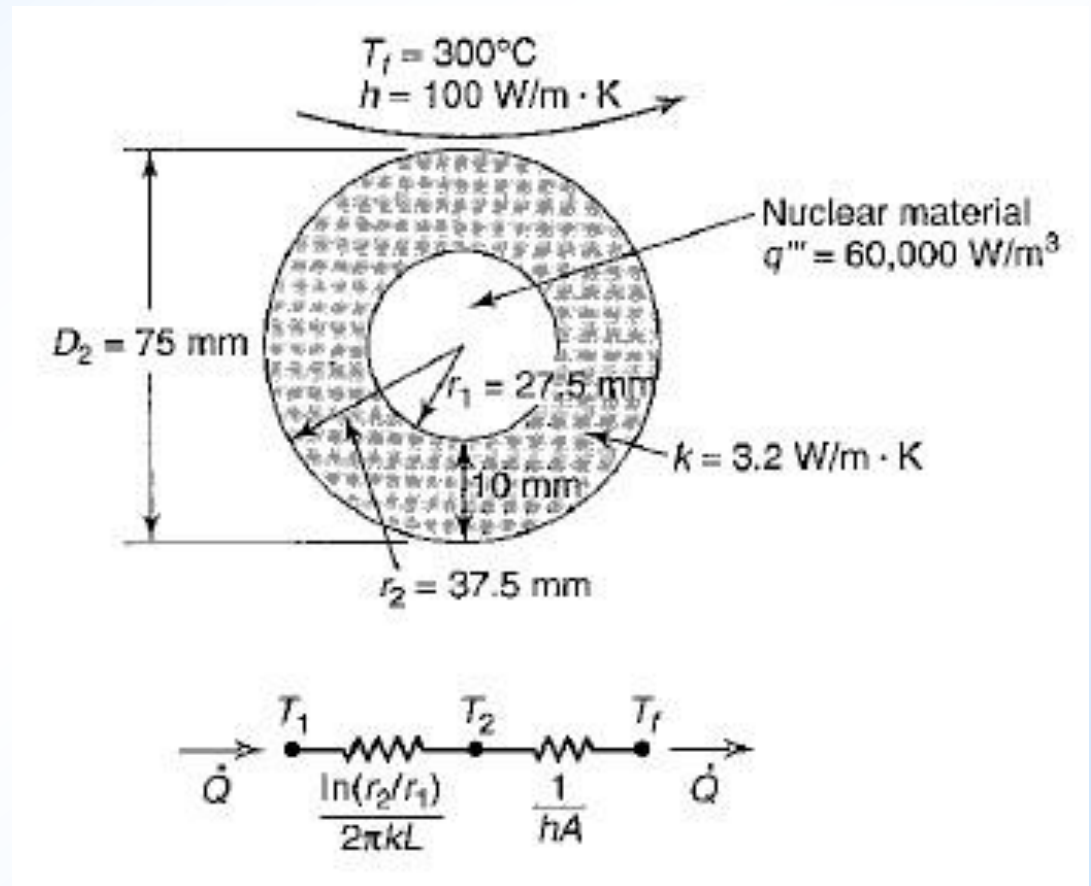



### 3.5.4 Cocentric Spheres

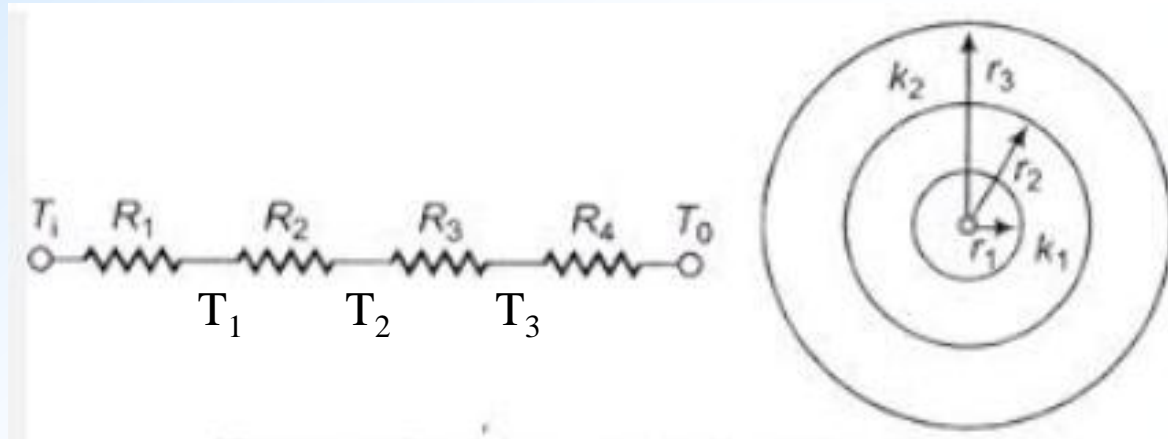

$$\dot{Q} = \frac{T_i - T_o}{R_{\text{total}}} = \frac{T_i - T_1}{R_1} = \frac{T_1 - T_2}{R_2} = \frac{T_2 - T_3}{R_3} = \frac{T_3 - T_o}{R_4}$$

$$R_1 = \frac{1}{4 \pi r_1^2 h_i} \quad R_2 = \frac{1}{4 \pi k_1} \frac{r_2 - r_1}{r_2 r_1} \quad R_3 = \frac{1}{4 \pi k_2} \frac{r_3 - r_2}{r_3 r_2} \quad R_4 = \frac{1}{4 \pi r_3^2 h_o}$$

For most engineering problems, the overall heat transfer coefficient,  $U$ , is based on the external (outer) surface area because the outer diameter can be easily measured.

$$U_o = \frac{1}{A_o R_{\text{total}}} = \frac{1}{4 \pi r_3^2 R_{\text{total}}}$$

$$U_o = \frac{1}{\frac{1}{h_1} \frac{r_3^2}{r_1^2} + \frac{r_2 - r_1}{k_1} \frac{r_3^2}{r_2 r_1} + \frac{r_3 - r_2}{k_2} \frac{r_3^2}{r_3 r_2} + \frac{1}{h_0}}$$

### Example 13

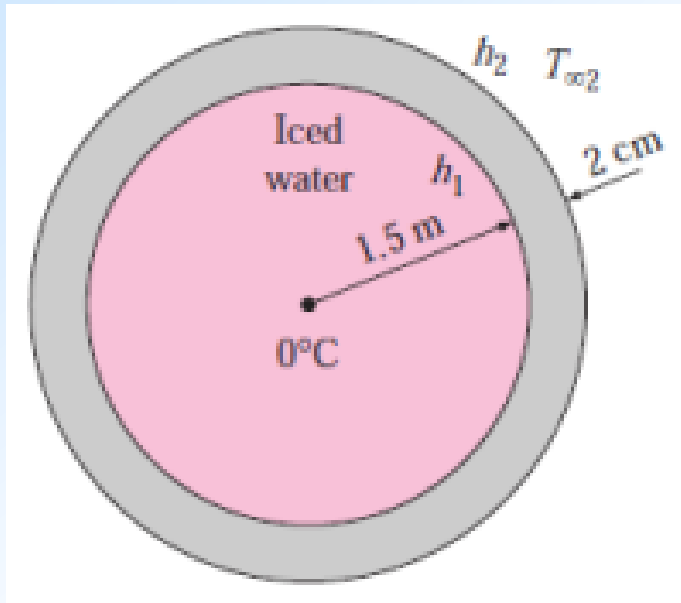

A 17 m internal diameter spherical tank made of 2 cm thick stainless steel ( $k = 15 \text{ W/m.K}$ ) is used to store iced water at  $T_{\infty,1} = 0 \text{ }^\circ\text{C}$ . The tank is located in a room whose temperature is  $T_{\infty,2} = 22 \text{ }^\circ\text{C}$ . The walls of the room are also at  $22 \text{ }^\circ\text{C}$ . The outer surface of the tank is black and heat transfer between the outer surface of the tank and the surroundings is by natural convection and radiation.

The convection heat transfer coefficients at the inner and the outer surfaces of the tank are  $h_1 = 80 \text{ W/m}^2\text{.K}$  and  $h_2 = 10 \text{ W/m}^2\text{.K}$ , respectively. Determine the rate of heat transfer to the iced water in the tank.

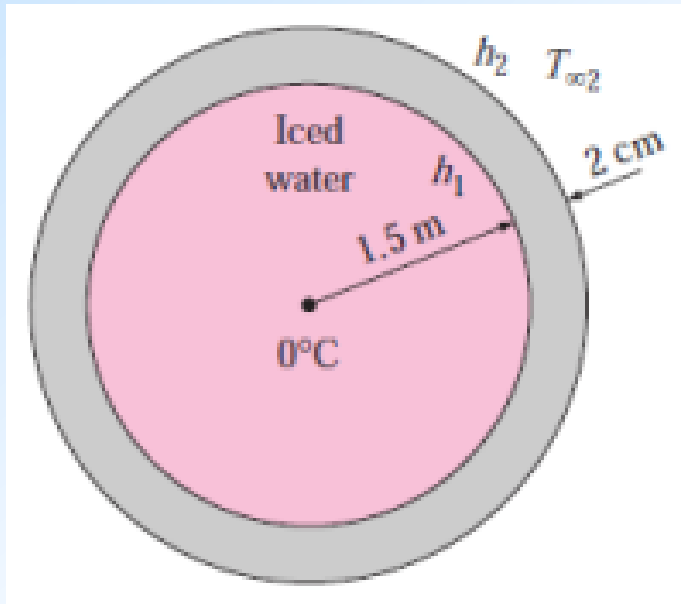

The thermal resistance network for this problem is in the Figure.

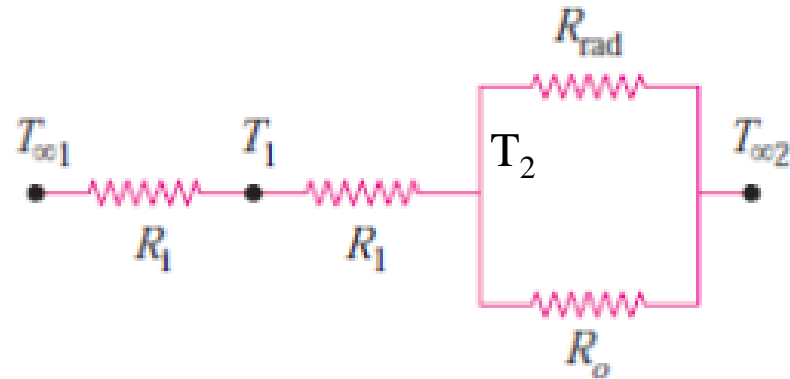

Inner surface area:  $A_1 = \pi D_1^2 = 28.3 \text{ m}^2$

Inner diameter:  $D_1 = 3 \text{ m}$

Outer surface area:  $A_2 = \pi D_2^2 = 29 \text{ m}^2$

Outer diameter  $D_2 = 3.04 \text{ m}$

The radiation heat transfer coefficient is given by:  $h_r = \varepsilon \sigma (T_2^2 + T_{\infty,2}^2) (T_2 + T_{\infty,2})$

$T_2$  is unknown. In order to calculate,  $h_r$ , a trial-and-error procedure is necessary.

Assume value for  $T_2$ , check this assumption later, and repeat the calculations if necessary using a revised value of  $T_2$ .

Note that  $T_2$ , must be between 0 °C and 22 °C, and closer to 0 °C since the heat transfer coefficient inside the tank is much larger.

Take  $T_2 = 5 \text{ °C} = 278 \text{ K}$ . Then

$$\begin{aligned} h_r &= \varepsilon \sigma (T_2^2 + T_{\infty,2}^2) (T_2 + T_{\infty,2}) = (1) (5.67 \cdot 10^{-8}) \left( (295)^2 + (278)^2 \right) (295 + 278) \\ &= 5.34 \text{ W/m}^2 \cdot \text{K} \end{aligned}$$

The other thermal resistances are:

$$R_i = R_{\text{conv},1} = \frac{1}{h_1 A_1} = \frac{1}{(80) (28.3)} = 0.000442 \text{ °C/W}$$

$$R_1 = R_{\text{sph}} = \frac{r_2 - r_1}{4 \pi k r_1 r_2} = \frac{1.52 - 1.50}{4 \pi (15) (1.52) (1.50)} = 0.000047 \text{ °C/W}$$

$$R_0 = R_{\text{conv},2} = \frac{1}{h_2 A_2} = \frac{1}{(10)(29)} = 0.00345 \text{ }^\circ\text{C/W}$$

$$R_{\text{rad}} = \frac{1}{h_r A_2} = \frac{1}{(5.34)(29)} = 0.00646 \text{ }^\circ\text{C/W}$$

Parallel resistances,  $R_0$  and  $R_{\text{rad}}$ , can be replaced by an equivalent resistance:

$$\frac{1}{R_{\text{eq}}} = \frac{1}{R_0} + \frac{1}{R_{\text{rad}}} = \frac{1}{0.00345} + \frac{1}{0.00646} = 444.7 \text{ W/}^\circ\text{C} \quad R_{\text{eq}} = 0.00225 \text{ }^\circ\text{C/W}$$

$$R_{\text{tot}} = R_i + R_1 + R_{\text{eq}} = 0.000442 + 0.000047 + 0.0025 = 0.00273 \text{ }^\circ\text{C/W}$$

$$\dot{Q} = \frac{T_{\infty,2} - T_{\infty,1}}{R_{\text{tot}}} = \frac{22 - 0}{0.00274} = 8029 \text{ W}$$

To check the validity of our original assumption ( $T_2 = 5 \text{ }^\circ\text{C}$ ), determine the outer surface temperature from

$$\dot{Q} = \frac{T_{\infty,2} - T_2}{R_{\text{eq}}} \quad \Rightarrow \quad T_2 = T_{\infty,2} - \dot{Q} R_{\text{eq}} = 22 - (8029) (0.00225) = 4 \text{ }^\circ\text{C}$$

The calculations need not to be repeated with  $T_2 = 4 \text{ }^\circ\text{C}$ . Why?

### 3.6 Thermal Contact Resistance

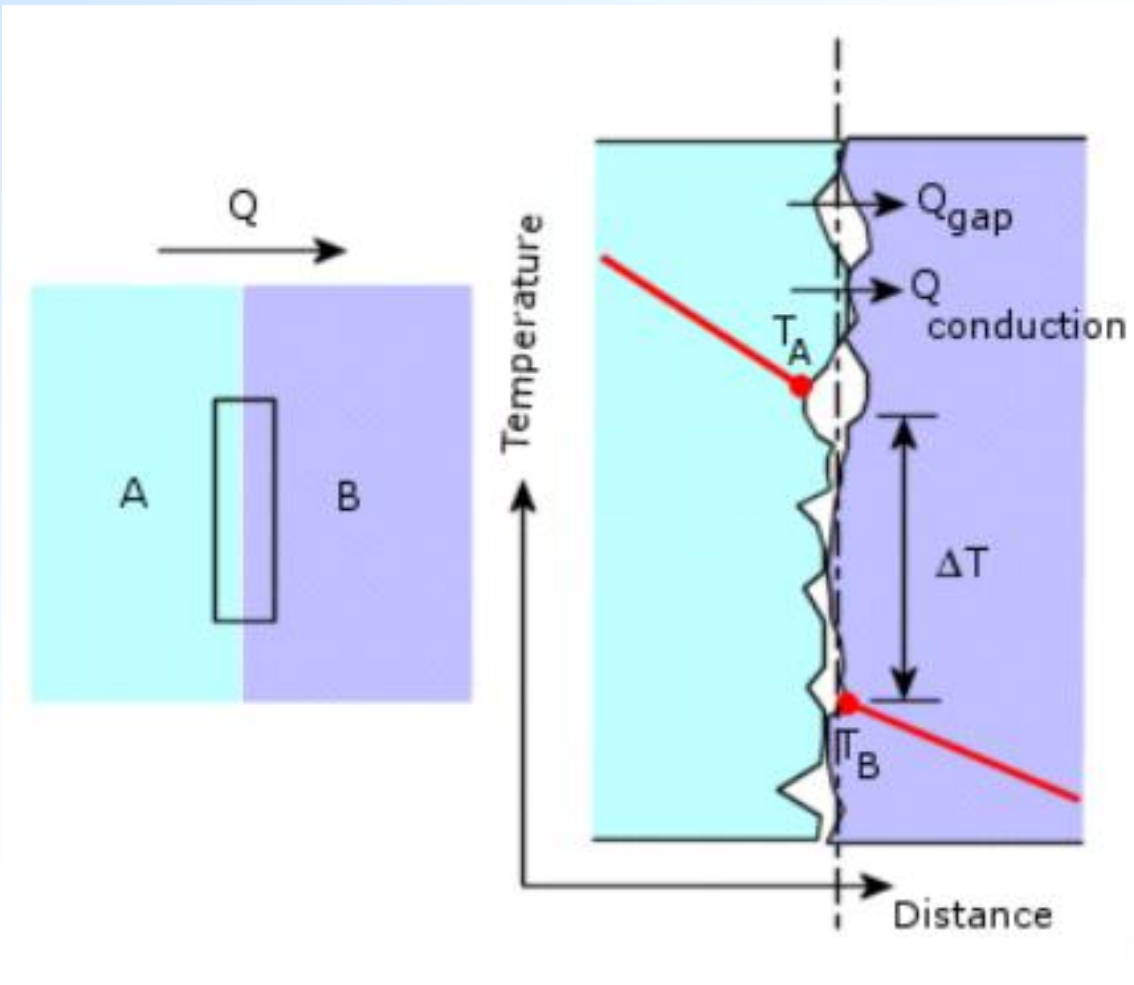

If two solids are not metallurgically bonded together, the enlarged view is as shown in the Figure.



The heat transfer across the actual contact points and the small air (gas) gaps is mainly by conduction. Radiation is negligible at room temperatures.

The thermal conductivity of a gas (air) is smaller than that of a solid. Therefore, the rate of heat flow is reduced due to the presence of stagnant gas in the gaps. The extra resistance to heat flow is called **thermal contact resistance**.

The interface thermal conductance  $h$  in  $W/m^2.K$  is determined by experiments. The reciprocal of  $h$ ,  $1/h$ , is called specific thermal contact resistance.  $R_{cont}$ .

$h$  increases with increasing interface pressure (increased solid to solid contact area) and decreases with increasing surface roughness and waviness.

## Example 14

A boiler wall is made up of two layers, A and B. Thickness and thermal conductivity of A are  $L_A = 240$  mm and  $k_A = 0.2$  W/m. $^{\circ}$ C, respectively. For B, thickness and thermal conductivity are  $L_B = 525$  mm and  $k_B = 0.3$  W/m. $^{\circ}$ C, respectively. Inner surface of A is maintained at  $T_1 = 1000$   $^{\circ}$ C and outer surface of B is maintained at  $T_4 = 250$   $^{\circ}$ C. There is a contact thermal resistance of  $R_{\text{cont}} = 0.050$   $^{\circ}$ C/W per unit area existing at the interface.

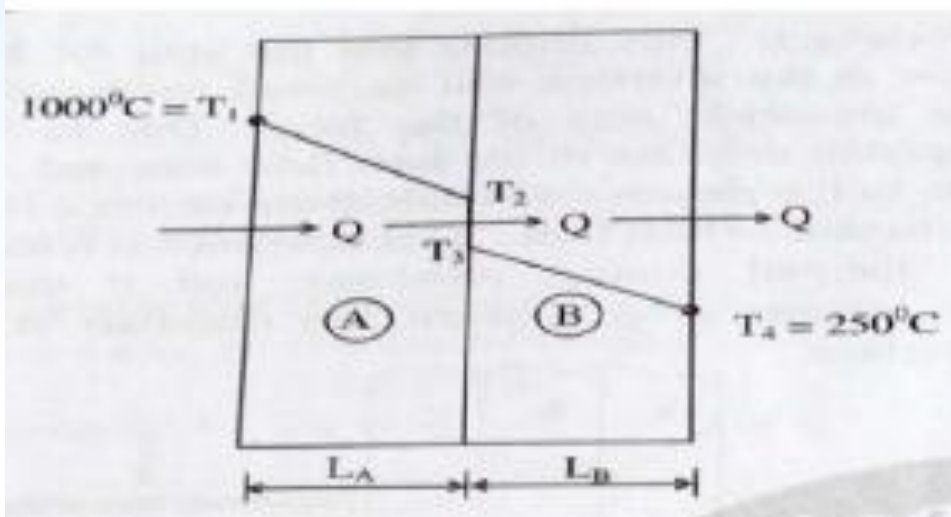

Calculate

- The heat lost per  $\text{m}^2$  area;
- The temperature drop at the interface.

Heat flux:  $\dot{q} = \frac{T_1 - T_2}{\frac{L_A}{k_A}} = \frac{T_3 - T_4}{\frac{L_B}{k_B}} = \frac{T_1 - T_4}{\frac{L_A}{k_A} + R_{\text{cont}} + \frac{L_B}{k_B}}$

$$\dot{q} = \frac{T_1 - T_4}{\frac{L_A}{k_A} + R_{\text{cont}} + \frac{L_B}{k_B}} = \frac{1000 - 250}{\frac{0.24}{0.2} + 0.05 + \frac{0.525}{0.3}} = 250 \text{ W/m}^2$$

$$250 = \frac{T_1 - T_2}{\frac{L_A}{k_A}} = \frac{1000 - T_2}{\frac{0.24}{0.2}} \Rightarrow T_2 = 700 \text{ }^\circ\text{C}$$

$$250 = \frac{T_3 - T_4}{\frac{L_B}{k_B}} = \frac{T_3 - 250}{\frac{0.525}{0.3}} \Rightarrow T_3 = 687.5 \text{ }^\circ\text{C}$$

## 3.7 Variable Thermal Conductivity

If we have a solid whose thermal conductivity strongly varies with temperature or if temperature differences are quite large, then this dependence has to be accounted for. In general, the solutions are complicated, but for one dimensional, steady state case, they are straight forward and relatively easier.

### 3.7.1 Slab with Variable Thermal Conductivity

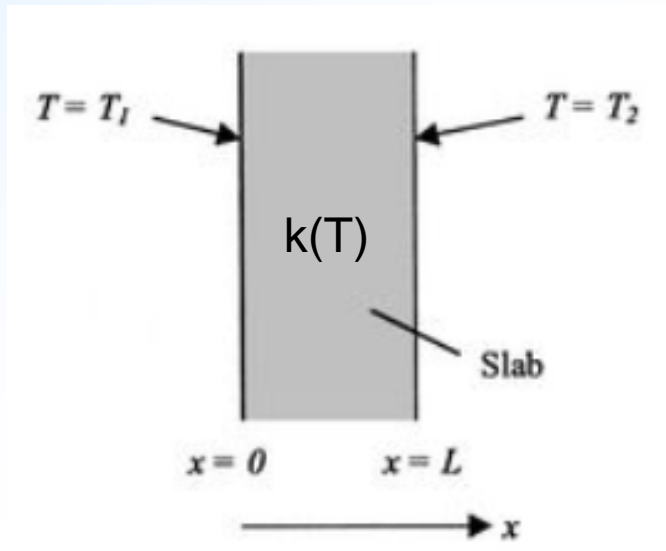

Differential Equation: 
$$\frac{d}{dx} \left( k(T) \frac{dT}{dx} \right) = 0$$

Boundary Conditions:

- (1)  $T = T_0$  at  $x = 0$
- (2)  $T = T_1$  at  $x = L$

Question:  $\dot{Q} = ?$

Solution:  $k(T) \frac{dT}{dx} = C \quad \Rightarrow \quad k(T) dT = C dx$

If  $k(T)$  is a known function of temperature, the distribution,  $T(x)$ , can easily be found.

Fourier's law:  $Q = A \dot{q} = -A k(T) \frac{dT}{dx} = -A C \quad \text{constant}$

Integrate both sides to find  $C$ :  $\int_{T_0}^{T_1} k(T) dT = C \int_0^L dx = C L \quad \Rightarrow \quad C = \frac{-1}{L} \int_{T_0}^{T_1} k(T) dT$

If  $k(T)$  is a linear function of temperature such as  $k(T) = k_0 (1 + \beta T)$

$$Q = \frac{A}{L} \int_{T_0}^{T_1} k_0 (1 + \beta T) dT = A k_0 \left( 1 + \beta \frac{T_0 + T_1}{2} \right) \left( \frac{T_0 - T_1}{L} \right)$$

If mean thermal conductivity is defined as  $k_m = k_0 \left( 1 + \beta \frac{T_0 + T_1}{2} \right)$

$$Q = A k_m \left( \frac{T_0 - T_1}{L} \right)$$

This is the same solution as before except that  $k$  is evaluated at the arithmetic mean temperature.

## Example 15

Determine the heat flux across 15 cm thick slab when one face is kept at  $T_1 = 500$  K and the other face at  $T_2 = 300$  K. The thermal conductivity varies linearly with temperature as  $k(T) = k_0 (1 + \beta T)$  where  $k_0 = 0.0346$  W/m.K and  $\beta = 0.0036$  K<sup>-1</sup>.

$$\begin{aligned}\dot{q} &= k_0 \left( 1 + \beta \frac{T_1 + T_2}{2} \right) \left( \frac{T_1 - T_2}{L} \right) \\ &= (0.0346) \left[ 1 + (0.0036) \left( \frac{500 + 300}{2} \right) \right] \left( \frac{500 - 300}{0.15} \right) \\ &= 112.57 \text{ W/m}^2\end{aligned}$$

### Example 16

A wafer of silicon, 3 mm thick and 2 cm square, is used in an electronic device. One side of the device is held at 85 °C and the other is held at 25 °C. The thermal conductivity of silicon varies with temperature as  $k = k_0 (1 + \beta T)$ , where  $k_0 = 15$  W/m.K,  $\beta = 0.00556$  °C<sup>-1</sup>, and  $T$  is in °C.

- Determine the HT rate (in W) if  $k$  is evaluated at its average temperature.
- Determine the HT rate (in W) if the temperature dependence of  $k$  is taken into account.

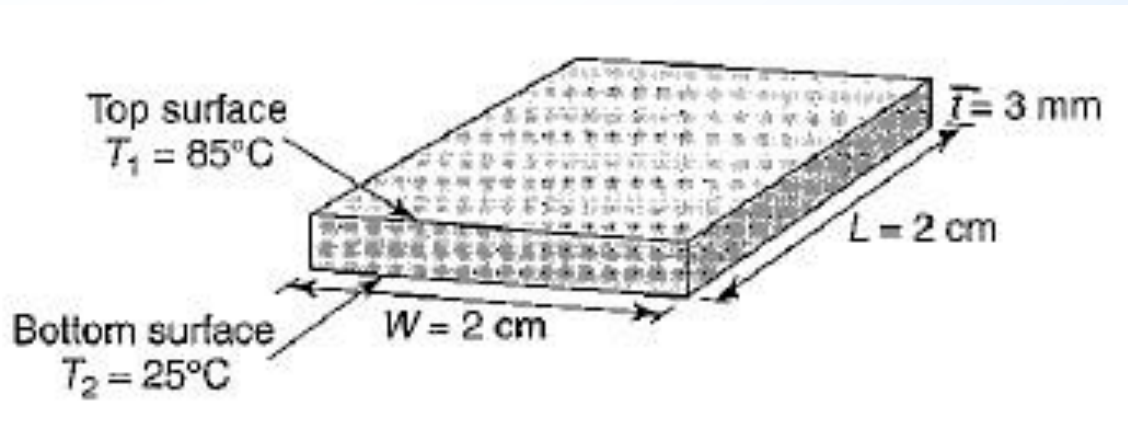



### 3.7.2 Hollow Cylinder with Variable Thermal Conductivity

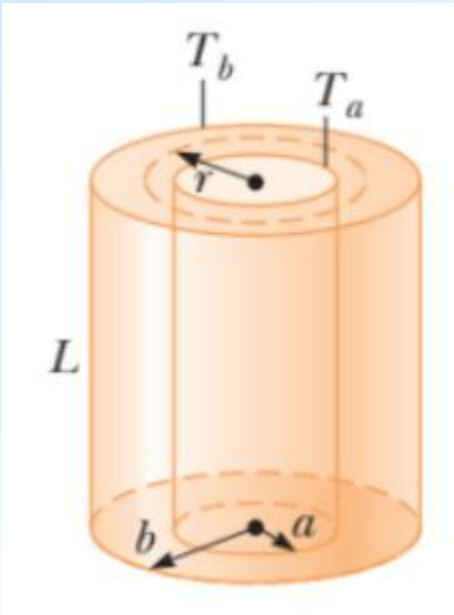

Differential Equation: 
$$\frac{d}{dr} \left( r k(T) \frac{dT}{dr} \right) = 0$$

Boundary Conditions:

- (1)  $T = T_a$  at  $r = a$
- (2)  $T = T_b$  at  $r = b$

Question:  $\dot{Q} = ?$

Solution: 
$$r k(T) \frac{dT}{dr} = C \quad \Rightarrow \quad k(T) dT = C \frac{dr}{r} \quad \Rightarrow \quad \int_{T_a}^{T_b} k(T) dT = C \int_a^b \frac{dr}{r}$$

$$C = \frac{-1}{\ln(b/a)} \int_{T_a}^{T_b} k(T) dT$$

$$\dot{Q} = 2 \pi r L \dot{q} = - 2 \pi r L \left[ k(T) \frac{dT}{dr} \right] = - 2 \pi r L \frac{C}{r} = - 2 \pi L C$$

$$\dot{Q} = \frac{2 \pi L}{\ln(b/a)} \int_{T_a}^{T_b} k(T) dT \quad \text{If } k(T) \text{ is known, } Q \text{ is calculated, easily.}$$

### 3.8 One-dimensional Fin Equation

Thin strips of metals called **fins (or extended surfaces)** are attached to the surface of a solid to increase the heat transfer area and hence the heat transfer by convection between the surface and the fluid surrounding it.

Fins are generally used on the surface where the convective heat transfer coefficient is low. Example: car radiator.



## Examples of Extended Surfaces - Fins

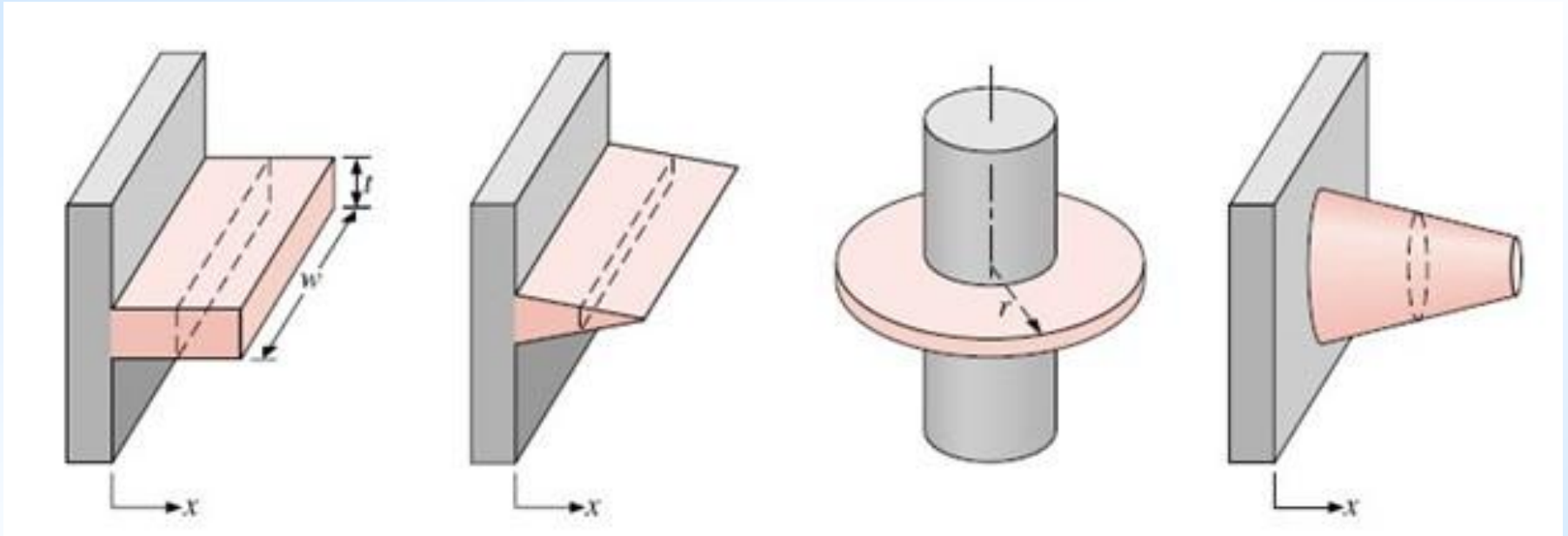

Straight Fins  
uniform and non-uniform cross section

Annular Fin

Pin Fin



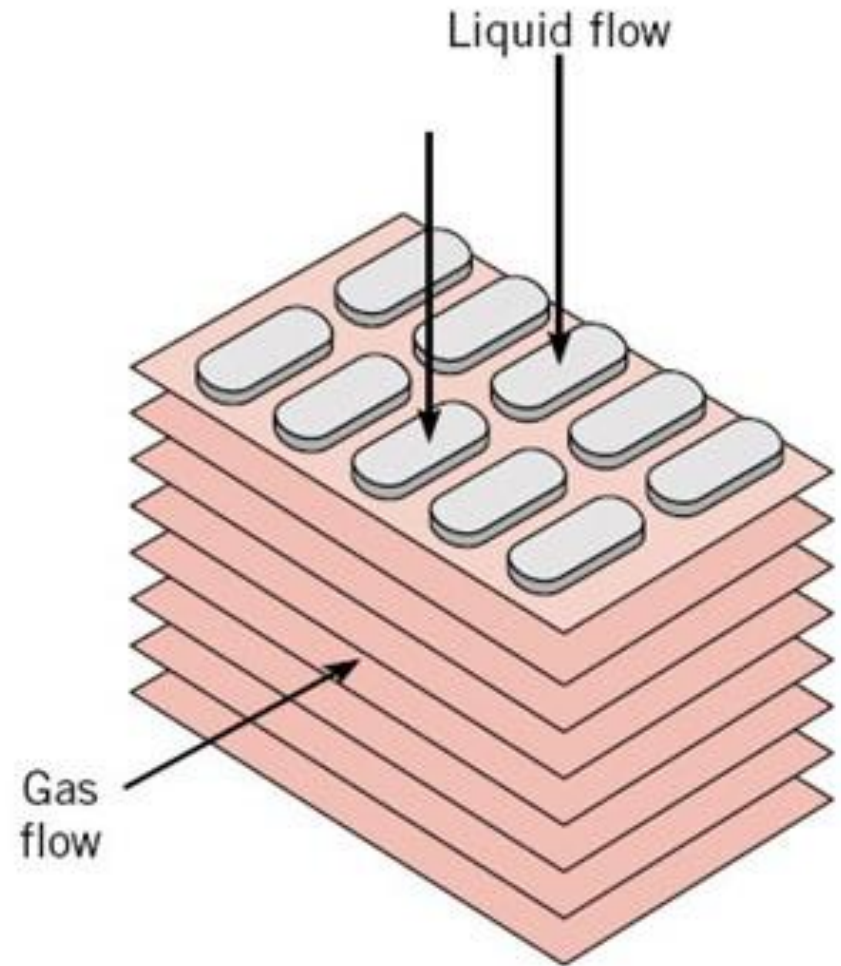
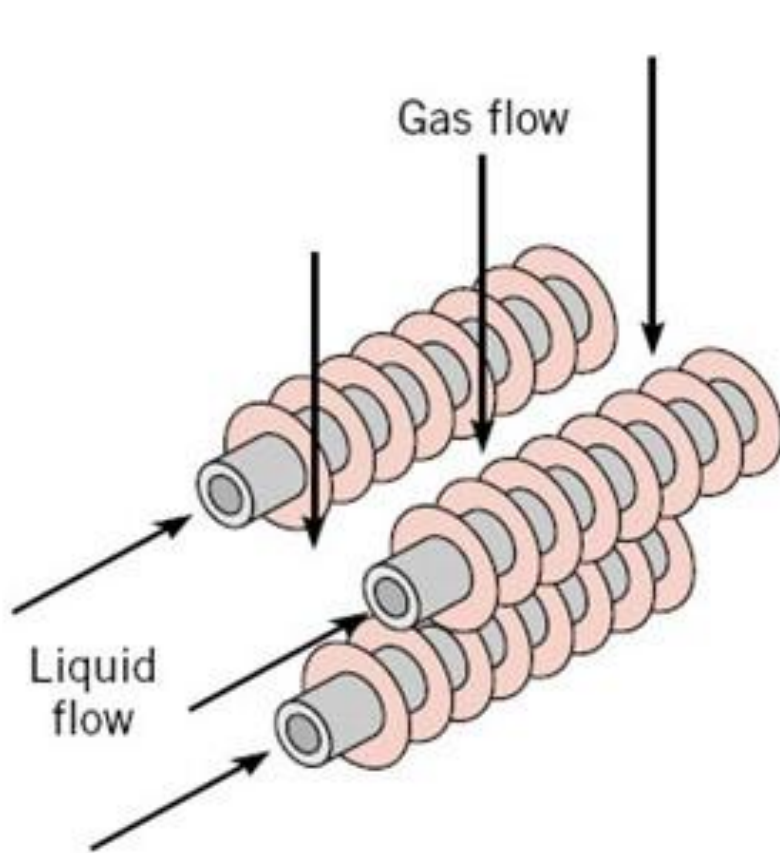

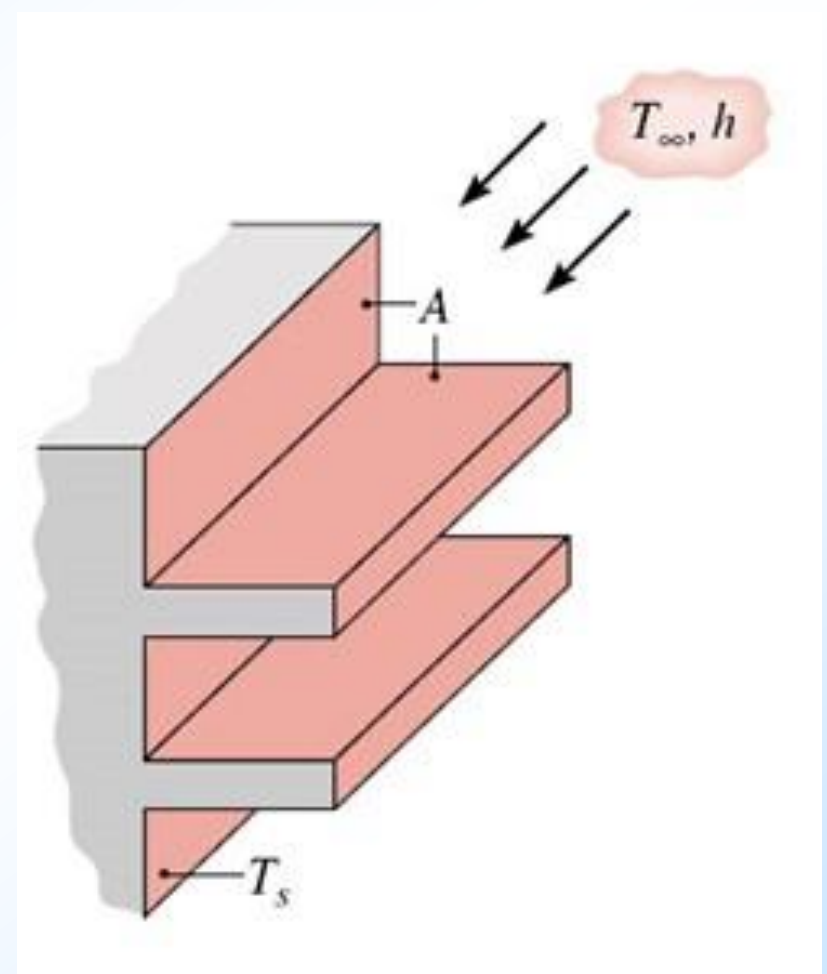
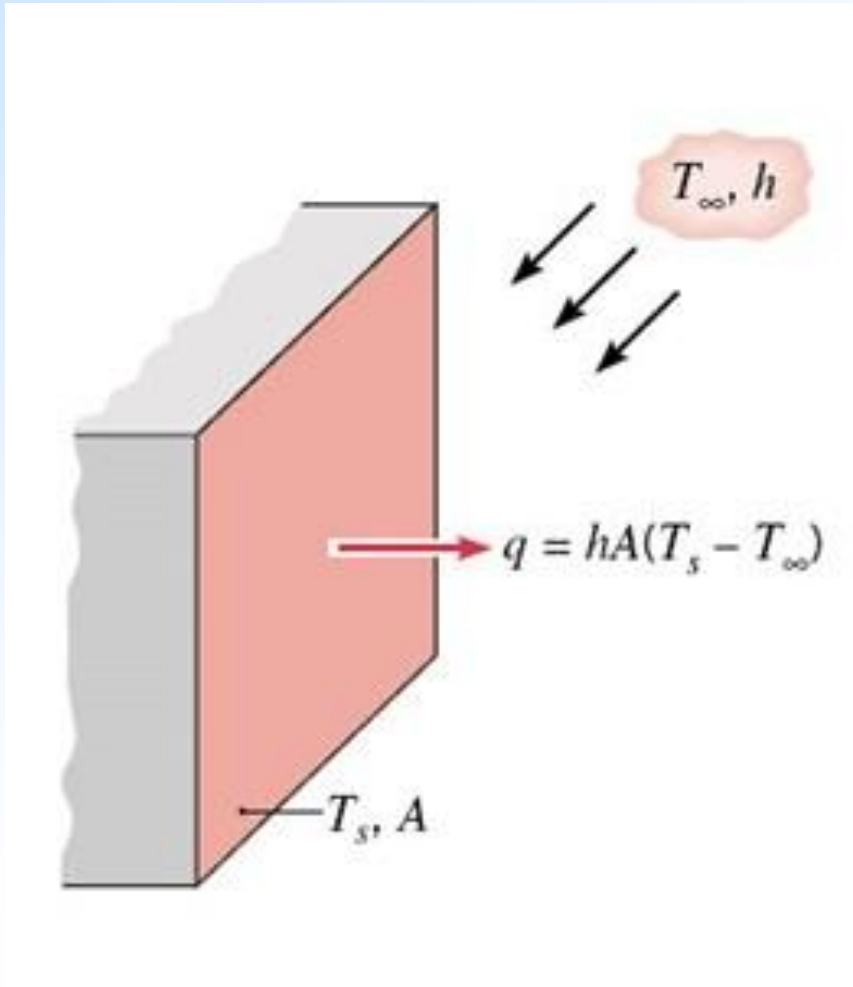

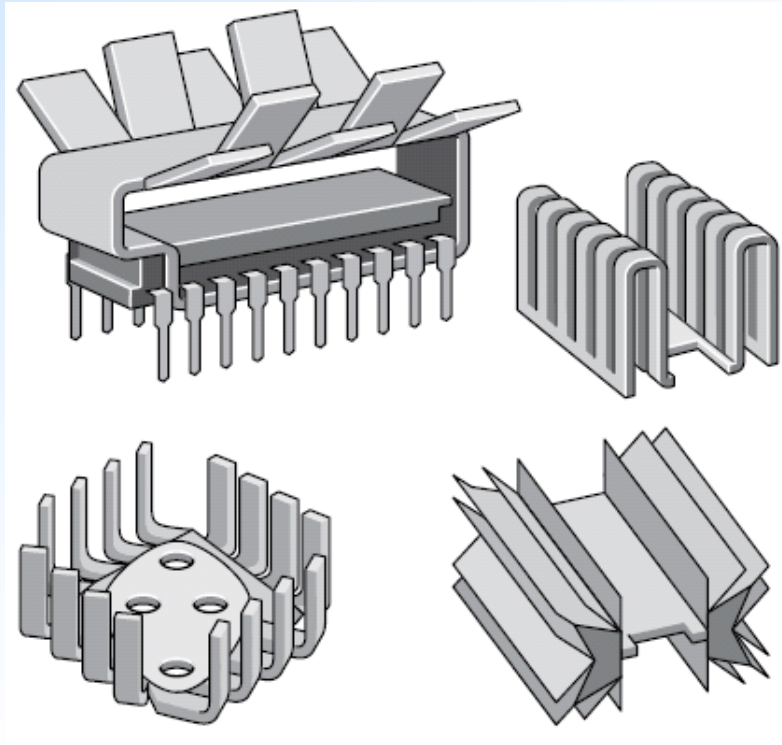

### Newton's Law of Cooling:

$$\dot{Q}_{conv} = A h (T_s - T_\infty)$$

Two ways to increase the rate of heat transfer:

- increasing the heat transfer coefficient;
- increase the surface area

➔ fins

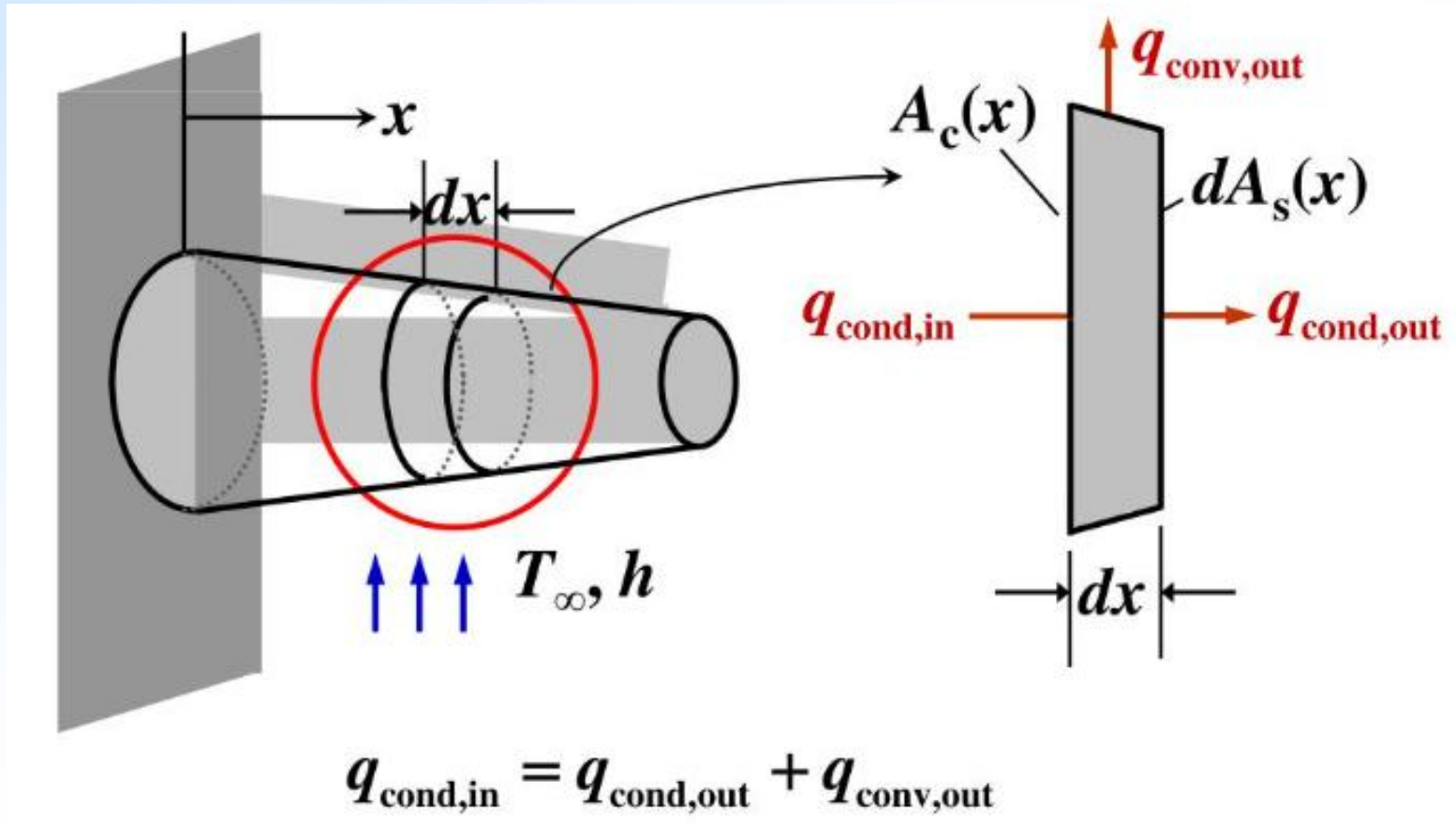



### 3.9 Temperature Distribution and Heat Flow in Fins of Uniform Cross Section

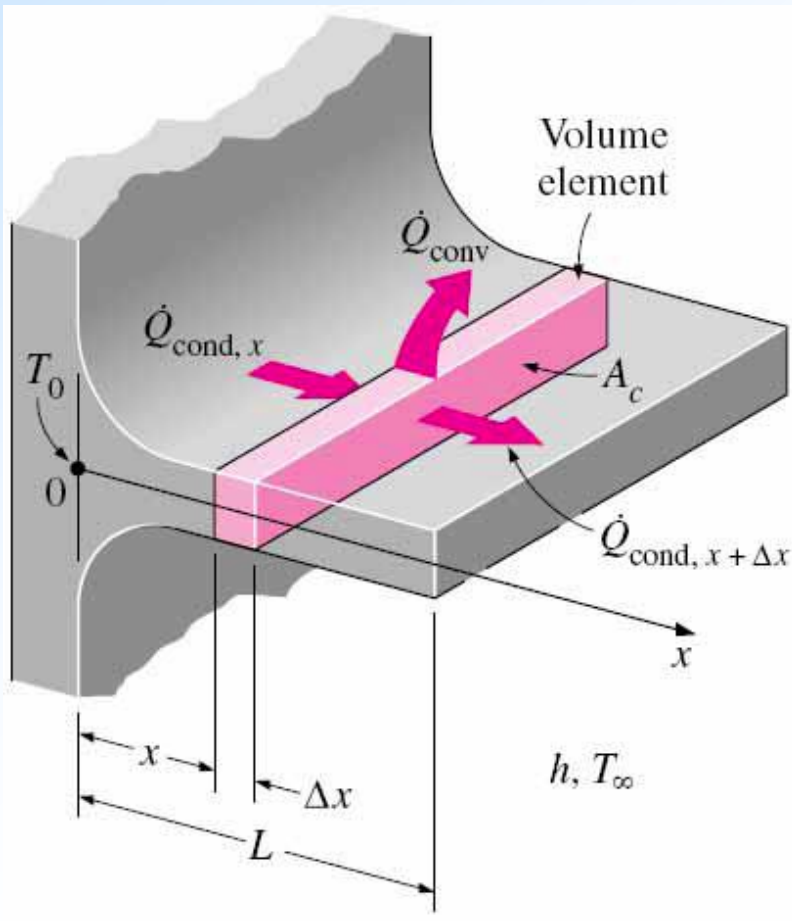

Under steady-state conditions, the energy balance on this volume can be expressed as

$$\left( \begin{array}{l} \text{Rate of heat} \\ \text{conduction into} \\ \text{the element at } x \end{array} \right) = \left( \begin{array}{l} \text{Rate of heat} \\ \text{conduction from} \\ \text{the element at } x+\Delta x \end{array} \right) + \left( \begin{array}{l} \text{Rate of heat} \\ \text{convection from} \\ \text{the element} \end{array} \right)$$

$$\dot{Q}_{cond,x} = \dot{Q}_{cond,x+\Delta x} + \dot{Q}_{conv}$$

$$\begin{aligned}\dot{Q}_{cond,x} &= \dot{Q}_{cond,x+\Delta x} + \dot{Q}_{conv} \\ &= \dot{Q}_{cond,x+\Delta x} + h (p \Delta x) (T - T_{\infty})\end{aligned}\quad \text{where } p \text{ is the perimeter}$$

$$\frac{\dot{Q}_{cond,x+\Delta x} - \dot{Q}_{cond,x}}{\Delta x} = h p (T - T_{\infty})$$

As  $\Delta x$  goes to zero:  $\frac{d\dot{Q}_{cond}}{dx} = h p (T - T_{\infty})$

From Fouries' Law:  $\dot{Q}_{cond} = -k A_c \frac{dT}{dx}$  where  $A_c$  is the cross-sectional area

$$\frac{d}{dx} \left( k A_c \frac{dT}{dx} \right) - h p (T - T_{\infty}) = 0$$

$$\frac{d}{d x} \left( k A_c \frac{d T(x)}{d x} \right) - h p (T(x) - T_\infty) = 0$$

For constant cross section,  $A_c$ , and thermal conductivity,  $k$ , and

defining:  $\theta(x) = T(x) - T_\infty$  and  $m = \sqrt{\frac{h p}{k A_c}}$

$$\frac{d^2 \theta}{d x^2} - m^2 \theta = 0$$

General Solution:  $\theta(x) = C_1 e^{m x} + C_2 e^{-m x}$

The constants,  $C_1$  and  $C_2$ , are to be determined from boundary conditions

Fin Equation:  $\frac{d^2\theta}{dx^2} - m^2 \theta = 0$      $\theta(x) = T(x) - T_\infty$     and     $m = \sqrt{\frac{h p}{k A_c}}$

General Solution(s):     $\theta(x) = C_1 e^{mx} + C_2 e^{-mx}$

$$\theta(x) = C_3 \cosh(mx) + C_4 \sinh(mx)$$

$$\theta(x) = C_5 \cosh(m(L-x)) + C_6 \sinh(m(L-x))$$

Which general solution is used depends on the given **boundary conditions**. Use the one which is easier to apply the BC's to determine the constants.

Remember the definitions to be used to convert one solution to the other.

$$\cosh(x) = \frac{e^x + e^{-x}}{2} \quad \text{and} \quad \sinh(x) = \frac{e^x - e^{-x}}{2}$$

## Boundary Conditions

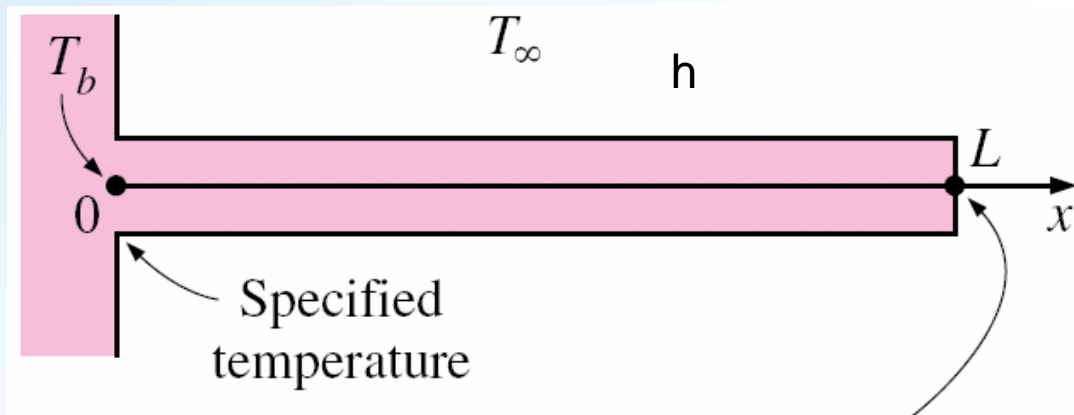

- (a) Specified temperature
- (b) Negligible heat loss
- (c) Convection
- (d) Convection and radiation

At the fin base ( $x = 0$ ):  $\theta(0) = \theta_b = T_b - T_\infty$

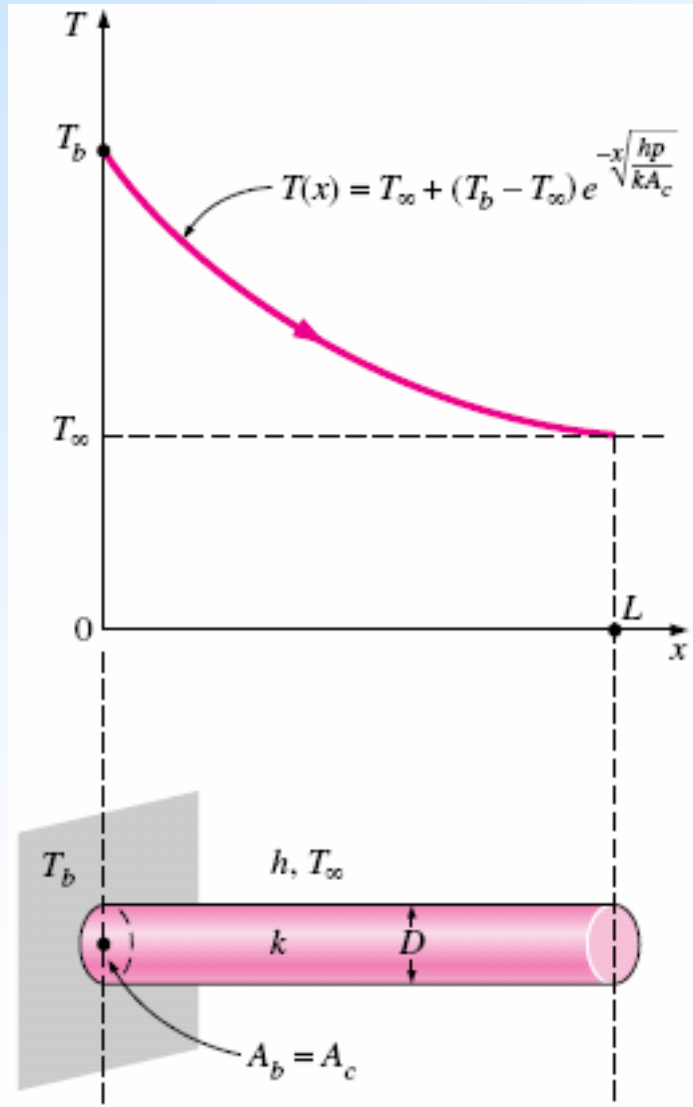

### 3.9.1 Infinitely(!) Long Fin $T_{\text{fin tip}} \Rightarrow T_{\infty}$

For a sufficiently long fin, the temperature at the fin tip approaches the ambient temperature, i.e.,  $T(L) \Rightarrow T_{\infty}$

The boundary condition becomes

$$\theta(x \rightarrow \infty) = T(L) - T_{\infty} \cong 0$$

Question: How long is “long”?

$$L \geq 5 \sqrt{\frac{k A_c}{h p}}$$

**Infinitely(!) Long Fin**  $T_{\text{fin tip}} \Rightarrow T_{\infty}$

Fin Equation:  $\frac{d^2\theta}{dx^2} - m^2 \theta = 0$   $m = \sqrt{\frac{hp}{kA_c}}$

General Solution:  $\theta(x) = C_1 e^{mx} + C_2 e^{-mx}$

Boundary Conditions:  $\theta(x \rightarrow \infty) = T(L) - T_{\infty} = 0 \Rightarrow C_2 \equiv 0$

$$\theta(0) = \theta_b = T_b - T_{\infty} \Rightarrow C_1 = \theta_b = T_b - T_{\infty}$$

$$\theta(x) = \theta_b e^{-mx} \Rightarrow \frac{T(x) - T_{\infty}}{T_b - T_{\infty}} = e^{-mx} = e^{-x \sqrt{\frac{hp}{kA_c}}}$$

**Infinitely(!) Long Fin**      $T_{\text{fin tip}} \Rightarrow T_{\infty}$

$$\theta(x) = \theta_b e^{-m x} \quad \Rightarrow \quad \frac{T(x) - T_{\infty}}{T_b - T_{\infty}} = e^{-m x} = e^{-x \sqrt{\frac{h p}{k A_c}}}$$

Total rate of heat transfer from the fin:

$$\dot{Q} = \int_{x=0}^{x=\infty} h p \theta(x) dx$$

$$\dot{Q} = -A_c k \left. \frac{d\theta}{dx} \right|_{x=0}$$

Both equations should give the same result:

$$\begin{aligned} \dot{Q} &= A_c k \theta_b m = \theta_b \sqrt{p h k A_c} \\ &= (T_b - T_{\infty}) \sqrt{p h k A_c} \end{aligned}$$



### 3.9.2 Fin with Adiabatic Tip (negligible heat flow at the tip)

Fin Equation: 
$$\frac{d^2\theta}{dx^2} - m^2 \theta = 0$$

General Solution: 
$$\theta(x) = C_3 \cosh(m(L - x)) + C_4 \sinh(m(L - x))$$

Boundary Conditions: 
$$\left. \frac{d\theta}{dx} \right|_{x=L} = 0 \quad \Rightarrow \quad C_4 \equiv 0$$

$$\theta(0) = \theta_b = T_b - T_\infty \quad \Rightarrow \quad C_3 = \frac{\theta_b}{\cosh(mL)}$$

$$\theta(x) = \theta_b \frac{\cosh(m(L - x))}{\cosh(mL)}$$

## Fin with Adiabatic Tip (negligible heat flow at the tip)

Temperature profile:  $\theta(x) = \theta_b \frac{\cosh(m(L-x))}{\cosh(mL)}$

Total rate of heat transfer from the fin:

$$\left. \dot{Q} = -A k \frac{d\theta}{dx} \Big|_{x=0} \right\} \begin{aligned} \dot{Q} &= \theta_b m A_c k \tanh(mL) \\ &= (T_b - T_\infty) \sqrt{p h k A_c} \tanh(mL) \end{aligned}$$

### 3.9.3 Fin with Convection at the Tip

Fin Equation: 
$$\frac{d^2\theta}{dx^2} - m^2 \theta = 0$$

General Solution: 
$$\theta(x) = C_3 \cosh(m(L - x)) + C_4 \sinh(m(L - x))$$

Boundary Conditions: 
$$\left. \begin{aligned} k \frac{d\theta}{dx} \Big|_{x=L} + h_{\text{tip}} \theta(L) &= 0 \\ \theta(0) &= \theta_b = T_b - T_\infty \end{aligned} \right\} \begin{array}{l} h_{\text{tip}} \text{ is not necessarily} \\ \text{equal to } h \end{array}$$

$$\theta(x) = \theta_b \frac{\cosh(m(L - x)) + \frac{h_{\text{tip}}}{m k} \sinh(m(L - x))}{\cosh(m L) + \frac{h_{\text{tip}}}{m k} \sinh(m L)}$$

## Fin with Convection at the Tip

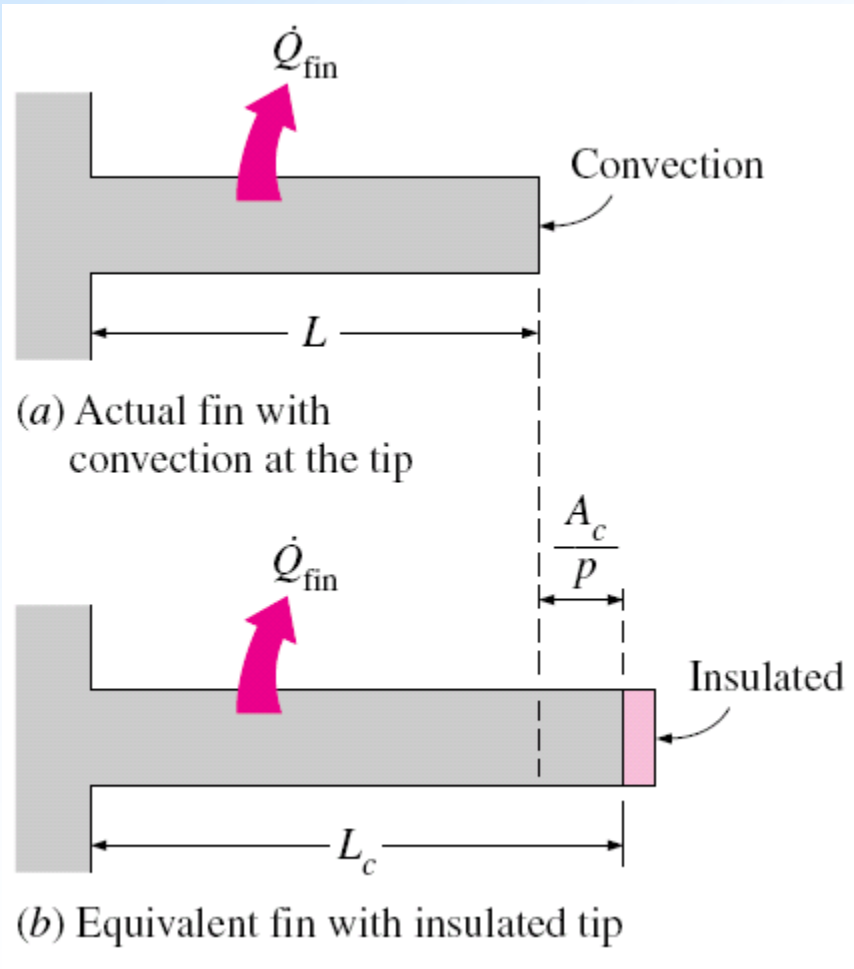

A practical way of accounting for the heat loss from the fin tip is to replace the *fin length*  $L$  in the relation for the *insulated tip case* by a **corrected length** defined as

$$L_c = L + \frac{A_c}{p}$$

$$L_{c, \text{rectangular}} \cong L + \frac{t}{2}$$

$$L_{c, \text{cylindrical}} \cong L + \frac{D}{4}$$

### 3.10 Fin Efficiency

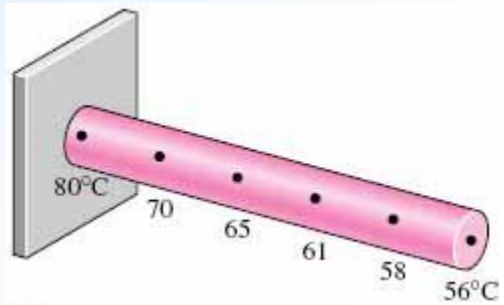
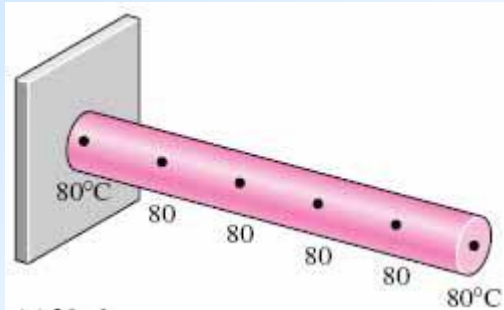

To maximize the heat transfer from a fin, the temperature of the fin should be uniform (maximized) at the base value of  $T_b$ .

In reality, the temperature drops along the fin, and thus the heat transfer from the fin is less.

To account for the effect, we define a **fin efficiency**:

$$\eta_{fin} = \frac{\dot{Q}_{fin}}{\dot{Q}_{fin,max}} = \frac{\text{Actual Heat Transfer Rate from the Fin}}{\text{Ideal Heat Transfer Rate from the Fin if the entire fin were at the base temperature}}$$

$$\dot{Q}_{fin} = \eta_{fin} h A_{fin} (T_b - T_{\infty})$$

In most cases, fins have variable cross sectional areas and that makes the solution complicated. For a variety of fin geometries the calculations are presented in terms of the fin efficiency.

$$\dot{Q}_{fin} = \eta_{fin} h A_{fin} (T_b - T_\infty) = \eta_{fin} h A_{fin} \theta_b$$

For the case of a fin with negligible heat flow at the tip:

$$A_{fin} = p L \quad \text{Where } p = \text{Perimeter of the fin and } L = \text{Length of the fin}$$

$$\dot{Q}_{ideal} = p L h \theta_b \quad \dot{Q}_{fin} = \theta_b \sqrt{p h k A_{fin}} \tanh(m L) \quad \text{as found before}$$

$$\eta_{fin} = \frac{\dot{Q}_{fin}}{\dot{Q}_{ideal}} = \frac{\theta_b \sqrt{p L k A_{fin}} \tanh(m L)}{\theta_b p L h}$$

$$\eta_{fin} = \frac{\tanh(m L)}{m L}$$

There are charts available that gives  $\eta_{fin}$  for various fin shapes as a function of

$L \sqrt{2 h / k t}$  where  $t$  is the thickness of the fin at the base.

The total heat transfer from a finned surface is:

$$\begin{aligned}\dot{Q}_{total} &= \dot{Q}_{fin} + \dot{Q}_{unfinned} \\ &= \eta_{fin} A_{fin} h \theta_b + (A_{total} - A_{fin}) h \theta_b\end{aligned}$$

As a practical guide, the ratio  $(p k / A h)$  should be much larger than unity to justify the use of fins. Although the surface area of heat transfer is increased, the thermal resistance over the portion of the surface where the fins are attached is also increased.

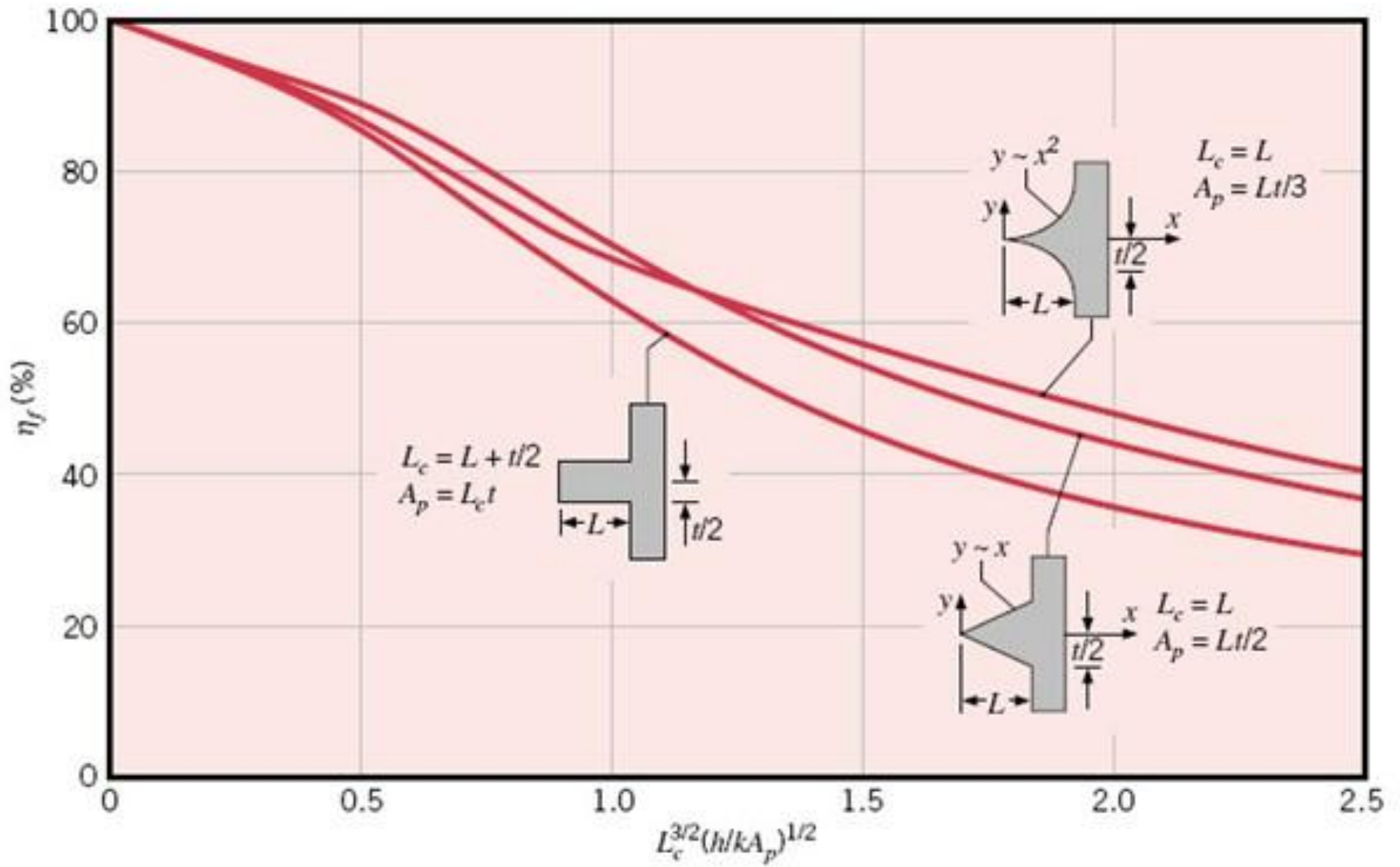



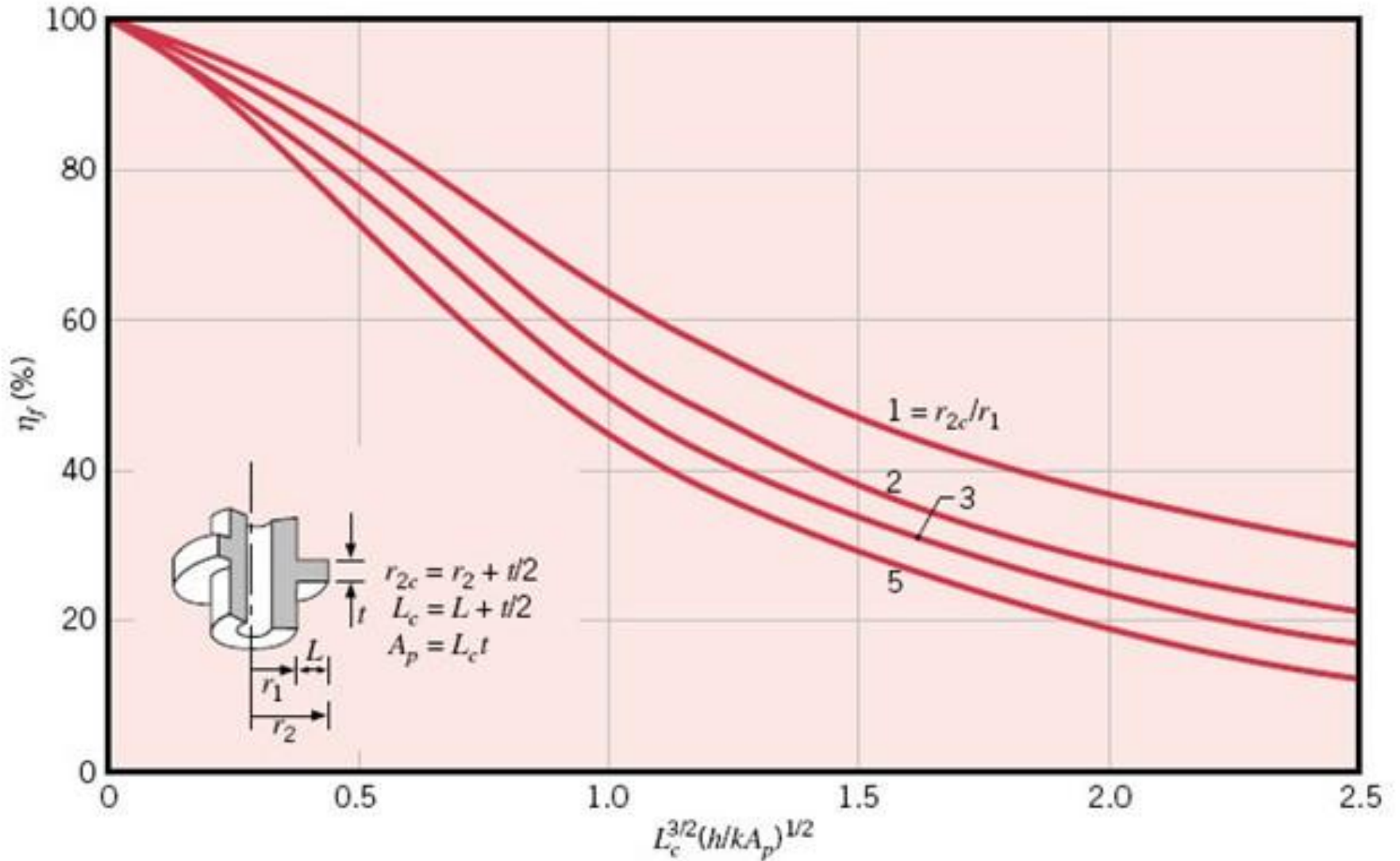

## Example 17

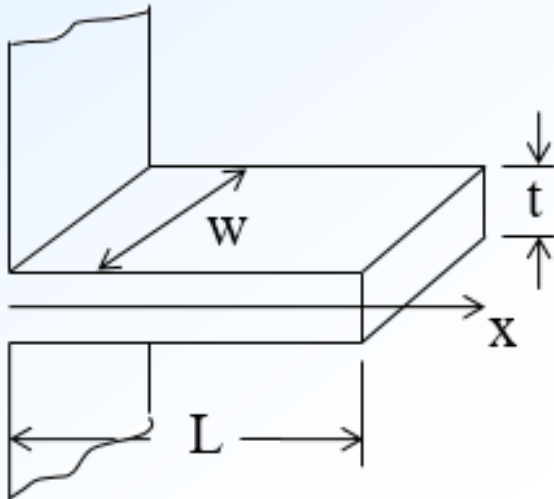

Compare  $\eta_{fin}$  of a plate fin of length  $L = 1.5$  cm, thickness  $t = 0.2$  cm, for the following cases:

- Fin material is Al ( $k = 207.64$  W/m.K) and  $h = 283.9$  W/m<sup>2</sup>.K
- Fin material is steel ( $k = 41.5$  W/m.K) and  $h = 510.9$  W/m<sup>2</sup>.K

Assume negligible heat loss from the tip.

$$\eta_{fin} = \frac{\tanh(m L)}{m L}$$

$$m = \sqrt{\frac{p h}{A_c k}} \cong \sqrt{\frac{2 h}{k t}}$$

$$m L \cong L \sqrt{\frac{2 h}{k t}}$$

$$\frac{p}{A_c} = \frac{2w + 2t}{wt} = \frac{2}{t} \left( 1 + \frac{t}{w} \right) \cong \frac{2}{t} \quad \text{if } w \gg t \quad \frac{t}{w} \cong 0 \text{ besides } 1$$

$$(a) \quad \eta_{fin} = \frac{\tanh(mL)}{mL} = \frac{\tanh \left[ (0.015) \sqrt{\frac{(2)(283.9)}{(207.64)(0.002)}} \right]}{(0.015) \sqrt{\frac{(2)(283.9)}{(207.64)(0.002)}}} = 0.91$$

$$(b) \quad \eta_{fin} = \frac{\tanh(mL)}{mL} = \frac{\tanh \left[ (0.015) \sqrt{\frac{(2)(510.9)}{(41.5)(0.002)}} \right]}{(0.015) \sqrt{\frac{(2)(510.9)}{(41.5)(0.002)}}} = 0.56$$

Solve the same problem using the fin-efficiency Figure.

## Example 18



Longitudinal thin fins are attached on the outer surface of a tube of inside radius  $r_a$ , outside radius  $r_b$ , and length  $L$ . The hot and cold fluids flowing inside and outside the tube have mean temperatures  $T_i$  and  $T_o$ , and heat transfer coefficients  $h_i$  and  $h_o$ , respectively.

The total heat transfer area on the outer surface of the tube, including the surface areas of the fins and the unfinned portion of the tube, is  $A_{tot}$  m<sup>2</sup> and the ratio of the fin surface area  $A_{fin}$  to the total heat transfer area  $A_{tot}$  is  $\beta$ . The fin efficiency  $\eta_{fin}$  and the thermal conductivity  $k$  of the tube material are given.

- a) Derive an expression for the heat transfer rate  $Q_{fin}$  through the finned tube.
- b) Compare  $Q_{fin}$  with the heat transfer rate  $Q_b$  for the case with no fins on the tube.

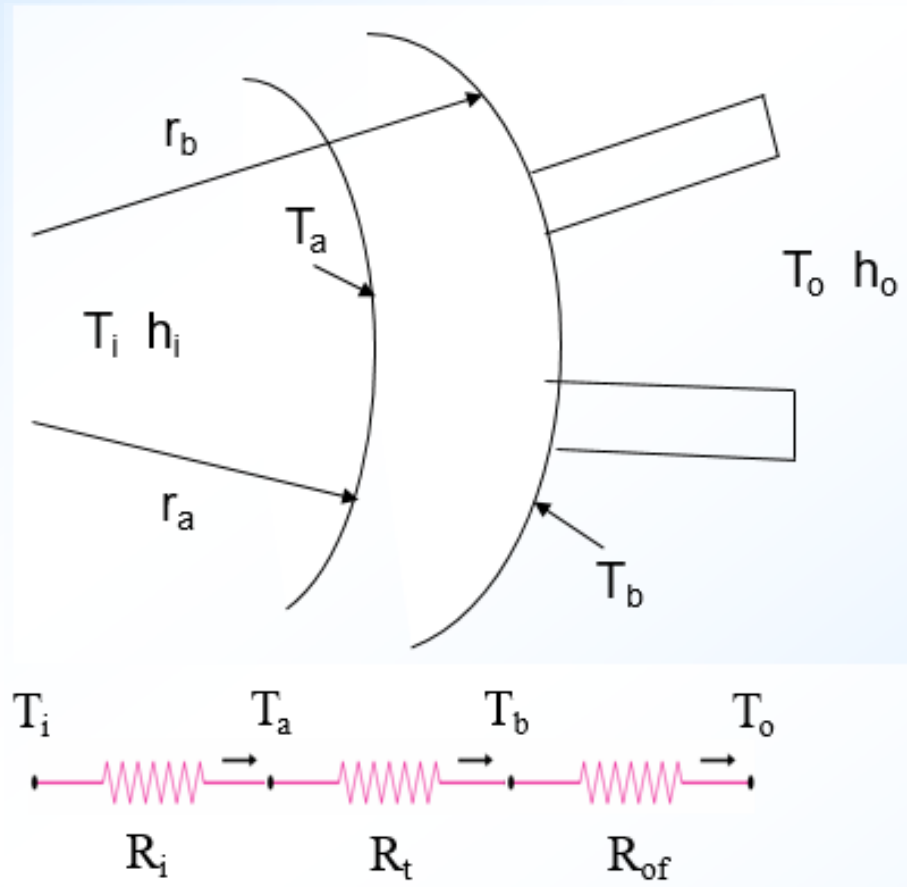

The thermal resistance concept can be used as shown in the Figure.

$R_{of}$  is the thermal resistance of the outside flow including the effects of the longitudinal fins.

Total heat transfer rate from the finned surface:

$$\dot{Q}_{fin} = \eta_{fin} A_{fin} h_o \theta_o + (A_{tot} - A_{fin}) h_o \theta_o$$

$$\dot{Q}_{fin} = \eta_{fin} \beta + (1 - \beta) A_{tot} h_o \theta_o \quad \text{if } \beta = \frac{A_{fin}}{A_{tot}}$$

Define area-weighted fin efficiency:  $\eta'_{fin} = \eta_{fin} \beta + (1 - \beta)$

$$\dot{Q}_{fin} = \eta'_{fin} A_{tot} h_o (T_b - T_o) = \frac{T_b - T_o}{R_{of}}$$

Therefore:  $R_{of} = \frac{1}{\eta'_{fin} A_{tot} h_o}$



Using the known temperatures,  $T_i$  and  $T_o$ , the total heat transfer rate from the finned surface becomes:

$$\dot{Q}_{\text{fin}} = \frac{T_i - T_o}{R_i + R_t + R_{\text{of}}}$$

$$R_i = \frac{1}{2 \pi r_a L h_i} \quad \text{and} \quad R_t = \frac{1}{2 \pi L k} \ln\left(\frac{r_b}{r_a}\right)$$

(b) If there are no fins:  $\dot{Q}_b = \frac{T_i - T_o}{R_i + R_t + R_o}$  where  $R_o = \frac{1}{2 \pi r_b L h_o}$

The ratio is:  $\frac{\dot{Q}_{\text{fin}}}{\dot{Q}_b} = \frac{R_i + R_t + R_o}{R_i + R_t + R_{\text{of}}}$

### 3.11 Fin Effectiveness

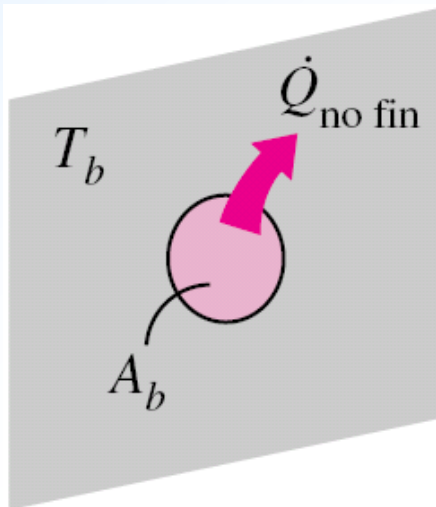
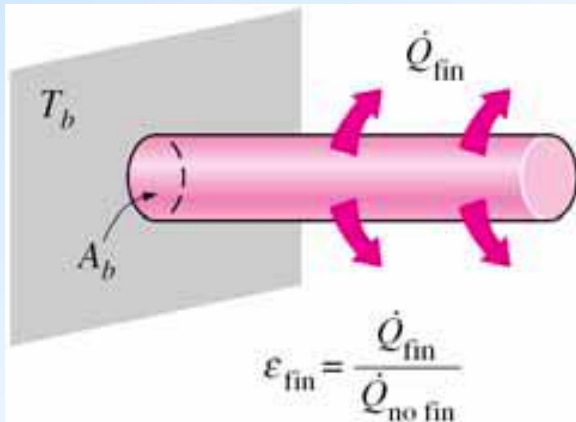

The performance of the fins is judged on the basis of the enhancement in heat transfer relative to the no-fin case.

The performance of fins is expressed in terms of the *fin effectiveness*  $\epsilon_{fin}$  defined as

$$\epsilon_{fin} = \frac{\dot{Q}_{fin}}{\dot{Q}_{no\ fin}} = \frac{\dot{Q}_{fin}}{h A_b (T_b - T_\infty)}$$



## Remarks Regarding Fin Effectiveness

- The *thermal conductivity  $k$  of the fin material* should be as high as possible. It is no coincidence that fins are made from metals.
- The ratio of the *perimeter to the cross-sectional area* of the fin  $p / A_c$  should be as high as possible.
- The use of fins is *most effective in applications* involving a *low convection heat transfer coefficient*.
- Hence, the use of fins is more easily justified when the medium is a *gas instead of a liquid*, and the heat transfer is by *natural convection instead of by forced convection*.

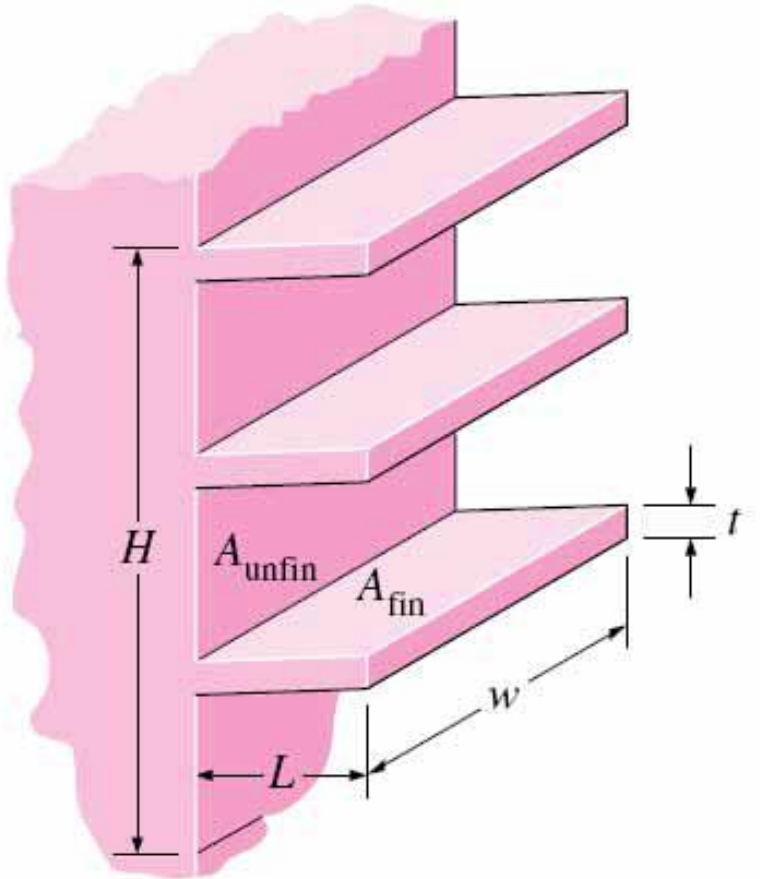

$$A_{no\ fin} = w \times H$$

$$A_{unfin} = w \times H - 3 \times (t \times w)$$

$$A_{fin} = 2 \times L \times w + t \times w$$

$$\cong 2 \times L \times w \text{ (one fin)}$$

## Overall Effectiveness

An **overall effectiveness** for a finned surface is defined as the ratio of the total heat transfer from the finned surface to the heat transfer from the same surface if there were no fins.

$$\epsilon_{fin,overall} = \frac{\dot{Q}_{fin}}{\dot{Q}_{no\ fin}} = \frac{h (A_{unfin} + \eta_{fin} A_{fin})}{h A_{no\ fin}}$$

### Proper Length of a Fin

An important step in the design of a fin is the determination of the appropriate length of the fin once the fin material and the fin cross section are specified.

The temperature drops along the fin exponentially and asymptotically approaches the ambient temperature at some length.

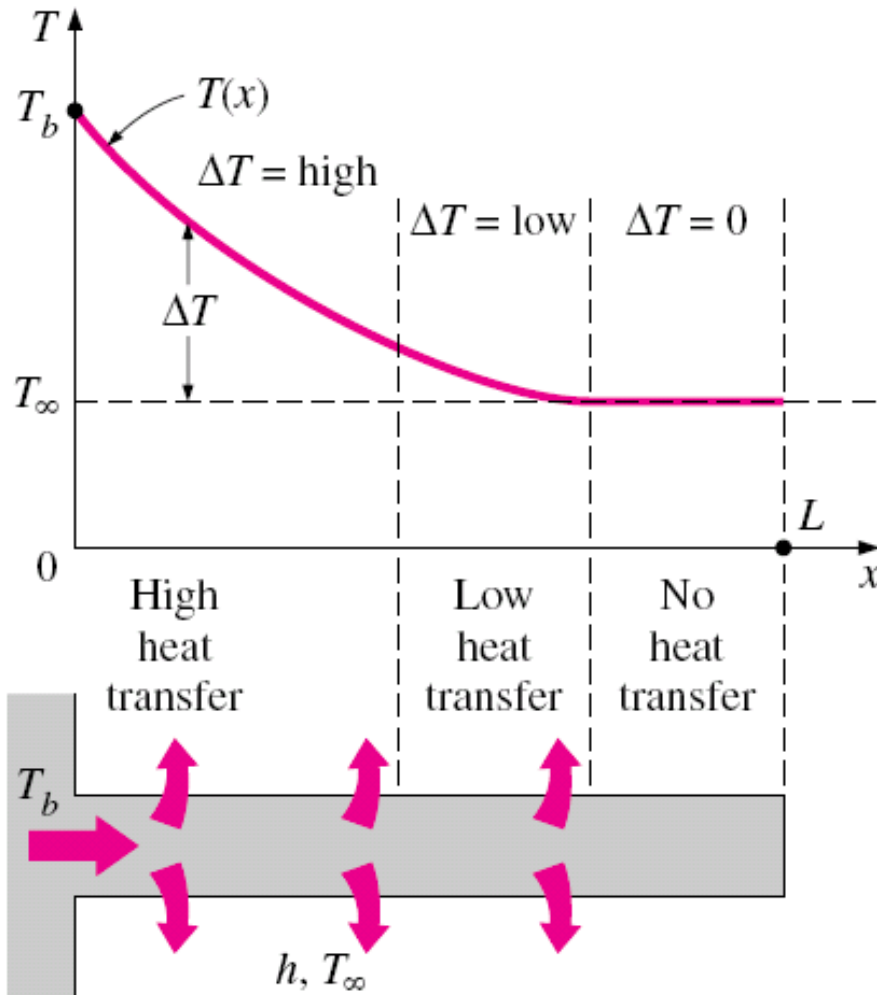

# Fin Arrays

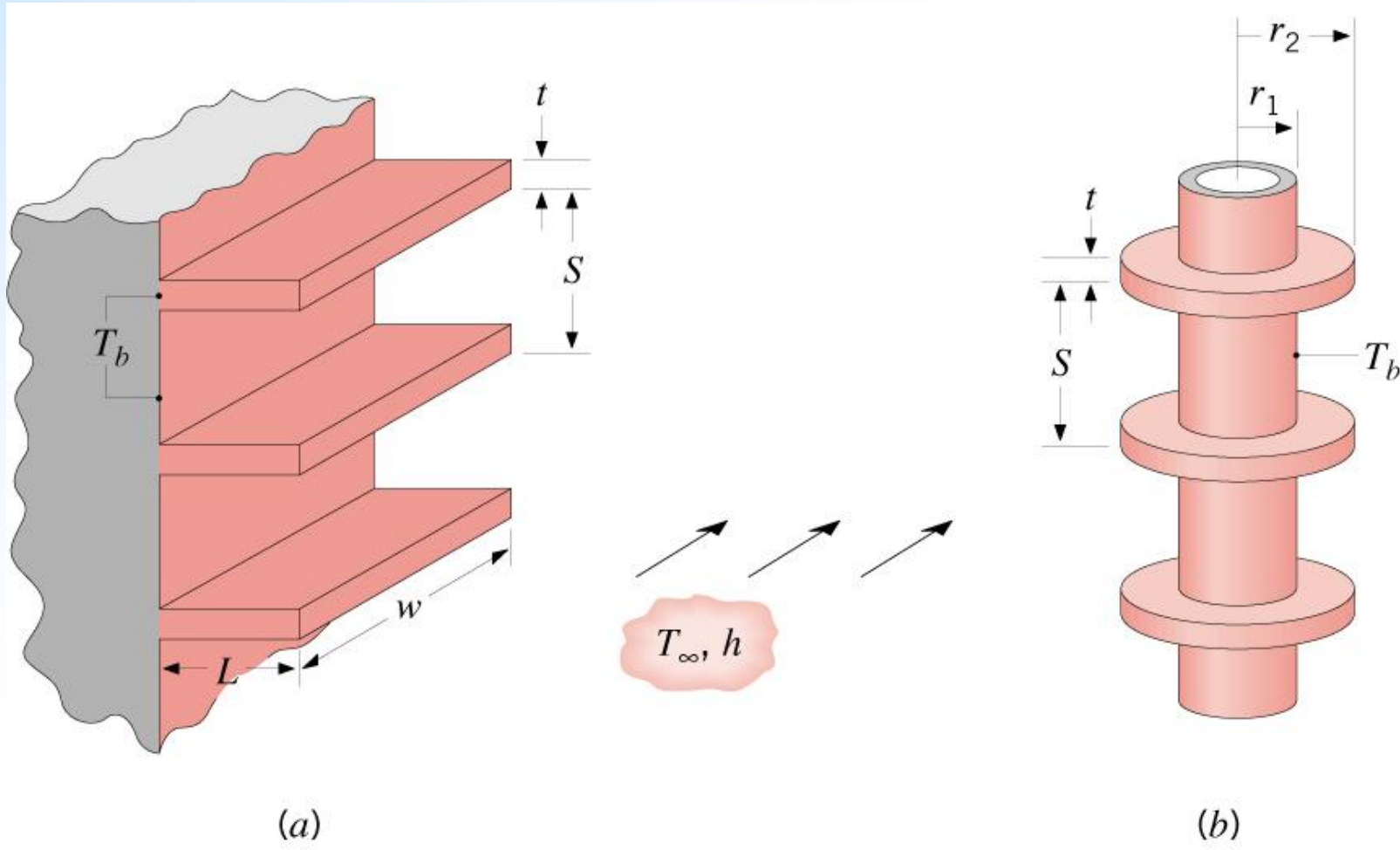

Total surface area:  $A_t = N A_f + A_b$

Number of fins  $\swarrow$   $\searrow$  Area of exposed base (*prime surface*)

Total heat flow rate:  $\dot{Q}_t = N \eta_f h A_f \theta_b + h A_b \theta_b = \eta_0 h A_t \theta_b = \frac{\theta_b}{R_{t,0}}$

Overall finned-surface efficiency:  $\eta_0 = 1 - \frac{N A_f}{A_t} (1 - \eta_f)$

Overall surface resistance:  $R_{t,0} = \frac{\theta_b}{\dot{Q}_t} = \frac{1}{\eta_0 h A_t}$

### Equivalent thermal circuit

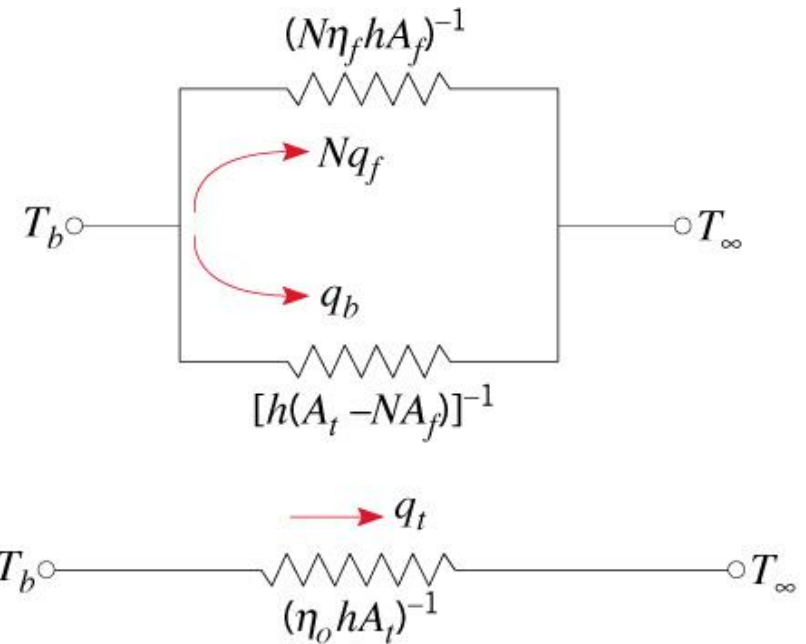
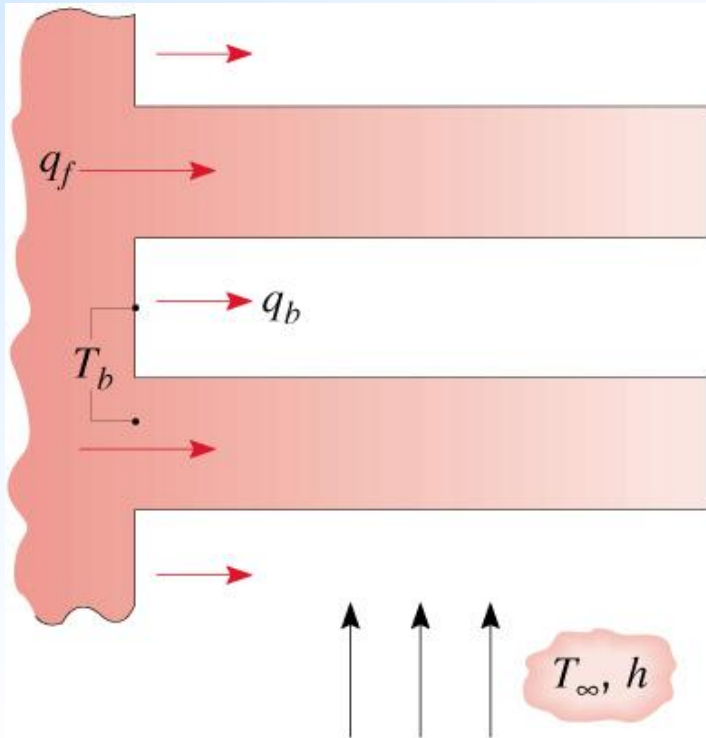

(a)

## Example 19

For the turbine blade and operating conditions shown in the figure,

- Determine whether blade temperatures are less than the maximum allowable value ( $1050\text{ }^{\circ}\text{C}$ ) for the prescribed operating conditions;
- Find the heat loss from the blade.

Assume adiabatic tip.

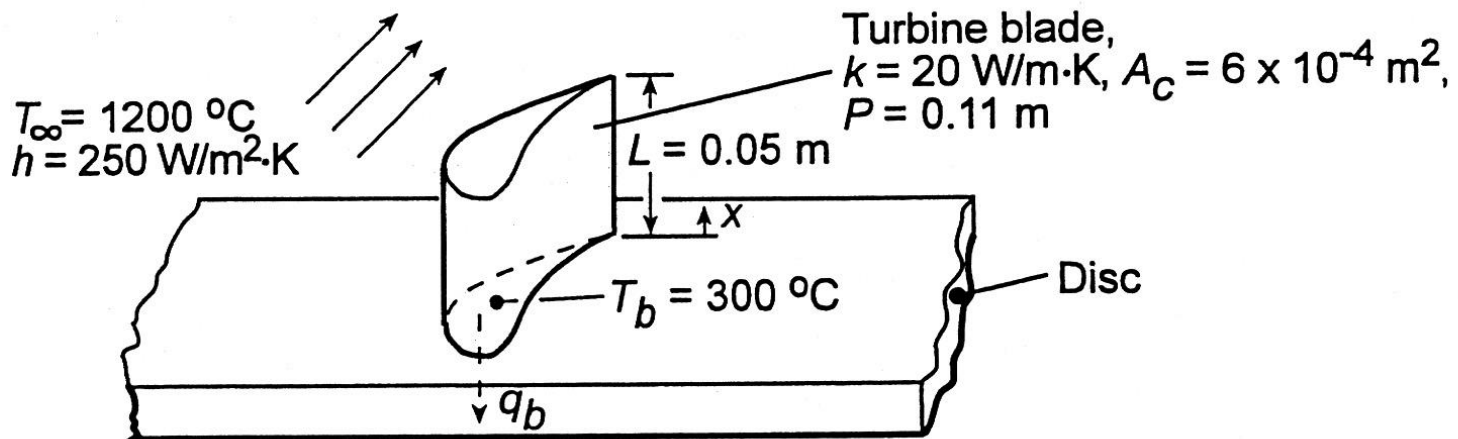



Assumptions:

- (1) One-dimensional, steady-state conduction in the blade, (2) Constant  $k$ ,
- (3) Adiabatic blade tip, (4) Negligible radiation.

Analysis: Conditions in the blade are determined by Case B of Table 3.4.

(a)

With the maximum temperature existing at  $x = L$ , Eq. 3.75 yields

$$\frac{T(L) - T_{\infty}}{T_b - T_{\infty}} = \frac{1}{\cosh(mL)} \quad m = \sqrt{\frac{h p}{k A_c}} = \sqrt{\frac{(250) (0.11)}{(20) (6 \cdot 10^{-4})}} = 47.87 \text{ m}^{-1}$$

$$m L = 47.87 \text{ m}^{-1} \times 0.05 \text{ m} = 2.59$$



$$\cosh(m L) = 5.51$$

$$T(L) = 1200 + \frac{300 - 1200}{5.51} = 1037 \text{ }^\circ\text{C}$$

*subject to the assumption of an adiabatic tip*, the operating conditions are acceptable.

(b)

$$M = \sqrt{h p k A_c} \theta_b = \sqrt{(250) (0.11) (20) (6 \cdot 10^{-4})} (-900) = -517 \text{ W}$$

$$Q_f = M \tanh(m L) = (-517) (0.983) = -508 \text{ W}$$

$$Q_b = -Q_f = 508 \text{ W}$$



### Comments:

Radiation losses from the blade surface contribute to reducing the blade temperatures, but what is the effect of assuming an adiabatic tip condition? Calculate the tip temperature allowing for convection from the gas.

### Example 20

Determine the maximum allowable power for a 20 mm x 20 mm electronic chip whose temperature is not to exceed 85 °C when the chip is attached to an air-cooled heat sink with N = 11 fins of prescribed dimensions.

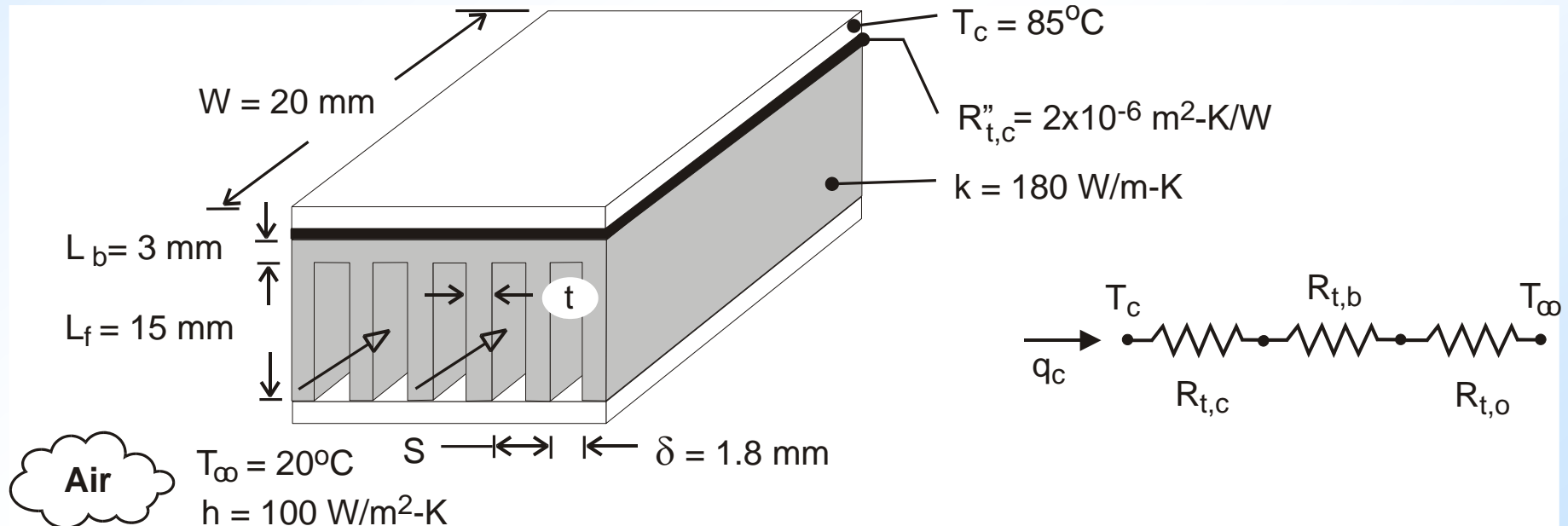

### 3.12 Critical Radius of Insulation

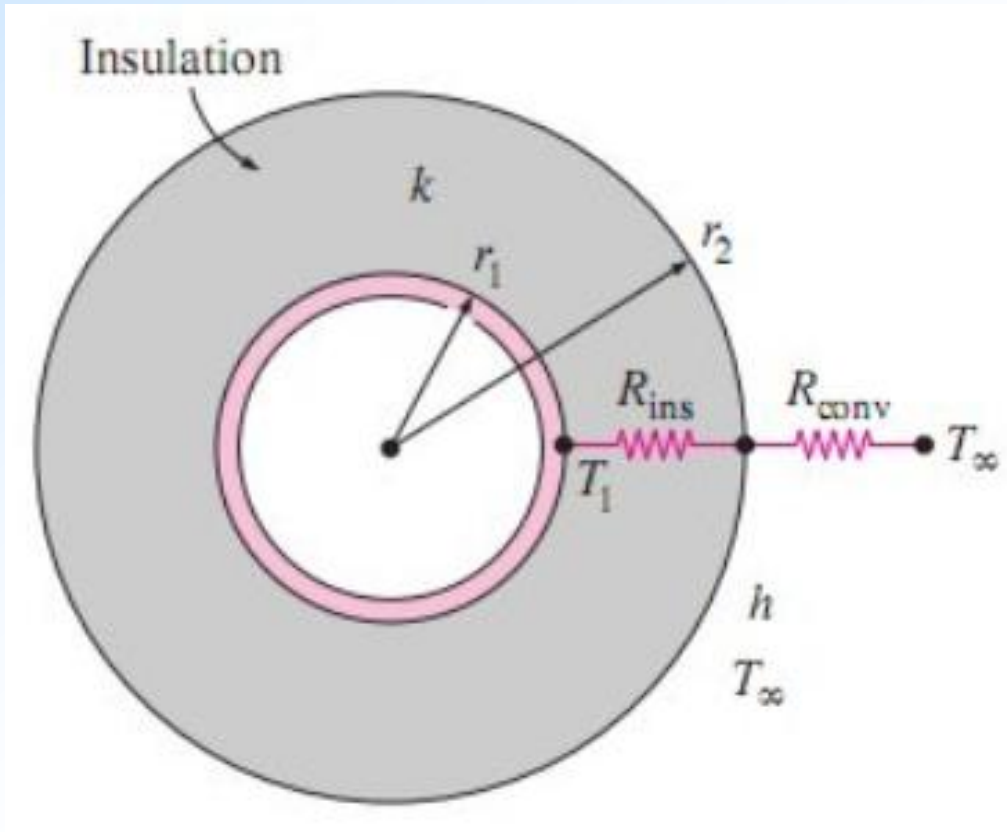

Consider the insulated cylinder shown in the Figure.  $T_1$  is kept constant.

$$\text{Heat flow rate: } \dot{Q} = \frac{T_1 - T_\infty}{R_{ins} + R_{conv}}$$

$$R_{ins} = \frac{1}{2 \pi L k} \ln \left( \frac{r_2}{r_1} \right)$$

$$R_{conv} = \frac{1}{2 \pi r_2 L h_o}$$

If  $r_2$  increases,  $R_{ins}$  increases, but  $R_{conv}$  decreases. What happens to  $Q$ ?

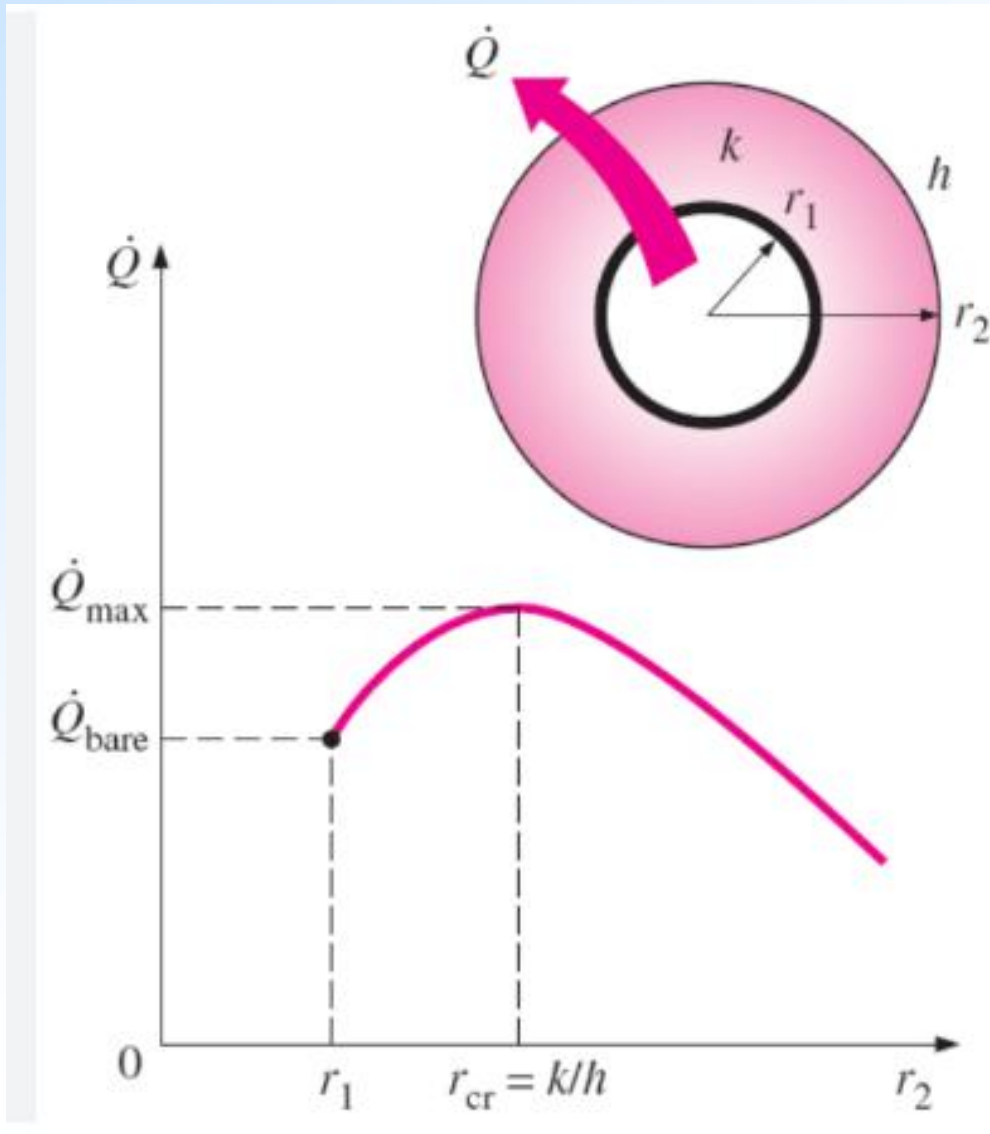

$\dot{Q}$  reaches a maximum value at a certain radius  $r_2$ , and this is called the critical radius of insulation,  $r_2 = r_{\text{cr}}$ .

Set the first derivative of  $\dot{Q}$  with respect to  $r_2$  equal to zero. The maximum occurs at  $r_{\text{cr}}$ .

$$r_{\text{cr}} = \frac{k}{h_o}$$

$$\frac{d\dot{Q}}{dr_2} = - \frac{2 \pi k L (T_1 - T_\infty)}{\left[ \ln\left(\frac{r_2}{r_1}\right) + \frac{k}{h_0 r_2} \right]^2} \left( \frac{1}{r_2} - \frac{k}{h_0 r_2^2} \right) = 0 \quad \Rightarrow \quad r_{cr} = \frac{k}{h_0}$$

Physical significance: Heat loss from a pipe increases with addition of insulation if pipe radius  $r_1$  is less than  $r_{cr}$  until  $r_{cr}$  is reached. Then, it starts to decrease.

If the effect of heat loss by radiation is included, the critical radius is somewhat lowered.

